

# SAILOR

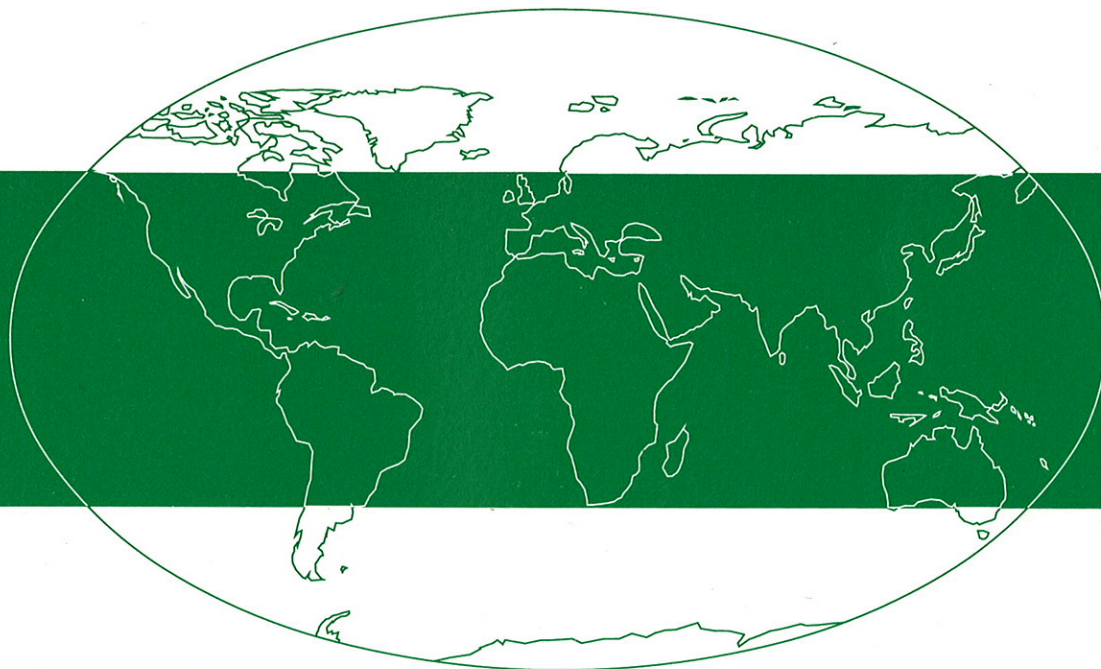

TECHNICAL MANUAL  
FOR  
COMPACT VHF DSC RM2042



S.P. RADIO A/S · AALBORG · DENMARK



## S.P. RADIO A/S

PORSVEJ 2 • DK-9200 AALBORG SV • DENMARK  
TEL. INT. + 45-98180999 • TELEX 69 789 SPRAD DK • TELEFAX + 45-98186717



## CONTENTS

1. INTRODUCTION
  - 1.1. GENERAL DESCRIPTION
  - 1.2. TECHNICAL DATA
  - 1.3. CONTROLS
  - 1.4. PRINCIPLE OF OPERATION AND BLOCK DIAGRAM
  
2. INSTALLATION
  - 2.1. MOUNTING POSSIBILITIES, DIMENSIONS AND DRILLING PLAN
  - 2.2. POWER SUPPLY
  - 2.3. HANDSET
  - 2.4. ANTENNA
  - 2.5. ELECTRICAL CONNECTIONS
  
3. SERVICE
  - 3.1. MAINTENACE
  - 3.2. ALIGNMENT INSTRUCTIONS
  - 3.3. PROPOSAL FOR NECESSARY TEST EQUIPMENT
  - 3.4. TROUBLE SHOOTING
  - 3.5. PERFORMANCE CHECK
  - 3.6. ADJUSTMENT PROCEDURE
    - 3.6.1. ADJUSTMENT OF INTERFACE (MODULE 1)
    - 3.6.2. ADJUSTMENT OF MICROPROCESSOR (MODULE 2)
    - 3.6.3. ADJUSTMENT OF RECEIVER (MODULE 3)
  - 3.7. REPLACEMENT OF COMPONENTS
  - 3.8. REPLACEMENT OF MODULES
  - 3.9. NECESSARY ADJUSTMENTS AFTER REPAIR

## CONTENTS cont.:

- 3.9.1. REPAIR/REPLACEMENT OF INTERFACE (MODULE 1)
- 3.9.2. REPAIR/REPLACEMENT OF MICROPROCESSOR (MODULE 2)
- 3.9.3. REPAIR/REPLACEMENT OF RECEIVER (MODULE 3)
- 3.10. PIN CONFIGURATIONS

## 4. MECHANICAL DESCRIPTION

- 4.1. MECHANICAL DISASSEMBLING AND MODULE LOCATION

## 5. CIRCUIT DESCRIPTION AND SCHEMATIC DIAGRAMS

- 5.1. INTERFACE (MODULE 1)
- 5.2. MICROPROCESSOR (MODULE 2)
- 5.3. RECEIVER (MODULE 3)
- 5.4. DISPLAY UNIT (MODULE 4)
- 5.5. KEYBOARD (MODULE 5)
- 5.6. INTERCONNECTION CABLE DIAGRAM

## 6. MICROTELEPHONE INSTALLATION

- 6.1. SPECIAL INSTALLATION WITH 2 MICROTELEPHONES
- 6.2. SPECIAL INSTALLATION WITH 3 MICROTELEPHONES

## 7. PARTS LIST

## CONTENTS

1. INTRODUCTION
- 1.1. GENERAL DESCRIPTION
- 1.2. TECHNICAL DATA
- 1.3. CONTROLS
- 1.4. PRINCIPLE OF OPERATION AND BLOCK DIAGRAM

## 1. INTRODUCTION

The RM2042 VHF receiver modem, has been developed to fulfill the international requirements stated by IMO, in the Global Maritime Distress and Safety System, known as GMDSS.

The RM2042 is the first self-contained receiver-modem on the market, which includes a separate receiver with continuous watch on calling ch. 70, and a full featured CLASS A modem for reception and generation of all types of calls.

Combined with a VHF in the compact 2000 program, a complete fully automatic VHF-communication system can be built. Furthermore the units can be combined with other compact 2000 units to form a complete GMDSS installation.

The RM2042 combines the IMO requirements on safety, with a lot of user convenient features to be used in normal VHF-communication. And of course a high security scrambler can be combined with the system.

This advanced communication controller uses a lot of front end technologies, including a complete new range of components as well as the well known mechatronic design. Resulting in a high quality product, able to withstand the harsh environmental conditions present at sea.

In spite of all the precautions taken in the design of this unit, a regular service and maintenance is recommended, to increase unit life-time and user safety.

S.P. Radio is the European leading manufacturer of maritime radio communication equipment - a position which has been maintained by means of constant and extensive product development. We have a world-wide network of dealers with general agencies in fifty countries. All our dealers are well-trained, and will be able to make service on all products.

## 1.1. GENERAL DESCRIPTION

- RM2042 is a complete VHF receiver-modem, for digital selective calling on the VHF-channels.
- RM2042 maintains a continuous watch of the calling channel 70, by means of the build-in receiver.
- RM2042 decodes and encodes all the messages applicable for a VHF Class A DSC-equipment, as prescribed by international authorities.
- RM2042 is intended for use, both as a part of the safety system on board, as well as a convenient automatic calling device ship/ship, ship/shore and when implemented from land telephone subscriber to ship.
- RM2042 can be connected to the C2149 GMDSS alarm unit, for remote control of distress calls.
- RM2042 has an output for an external alarm unit, indicating reception of distress calls.
- RM2042 has an NMEA0183-input, for direct connection to on-board navigational equipment, giving automatic position update in DSC calls.
- RM2042 can be connected to a standard line printer for print out of received messages and other valuable informations.
- RM2042 includes as a standard, an electronic memory message bank for different kinds of calls.
- RM2042 includes a user programable quick-call register, not only for numbers, but for complete user composed DSC-calls.
- RM2042 includes a real-time clock with battery back-up.
- RM2042 uses a fully alpha-numeric LCD-display, for read-out of all kinds of messages in plain language.
- RM2042 supplies the user with a menu-guided programming interface, making it an easy task to compose all kinds of calls.
- RM2042 can be used for channel selection on your new Compact 2000 VHF transceiver.
- RM2042 is housed in a corrosion resistant metal cabinet with a green nylon finish.
- RM2042 can of course be used in a manual set-up, as a DSC-encoder, providing the connected VHF-unit with key information etc.

## 1.2. TECHNICAL DATA

Complies with IMO, ITU, CEPT and other national requirements.

### GENERAL

Operation:	As CCIR Rec. 541-3
Protocol:	As CCIR Rec. 493-4 as VHF Class A equipment.
Printer Interface:	Parallel Centronics.
Navigator Interface:	NMEA 0183
Power Supply:	12V DC -10% to +30%
Power Consumption:	Standby typ. 0.1A Maximum 0.4A
Temperature Range:	-20 C to +55 C
Dimensions:	Height: 98mm Width : 225mm Depth : 150mm
Weight:	App. 2kg.

### RECEIVER WITH DECODER

Receiver frequency:	156.525MHz.
Sensitivity:	Symbol error rate below 0.01 at 0.25uV pd.
Spurious radiation:	Less than 2nW.

### ENCODER

Modulation:	1700 Hz +- 400 Hz 1200 Baud +- 30 ppm
Output level:	Adjustable between +-10 dBm in 600 ohms balanced output.
Tx key information:	Vcc or GND.
Programable encoder output delay:	1 mSec. to 255mSecs.



## 1.3. CONTROLS

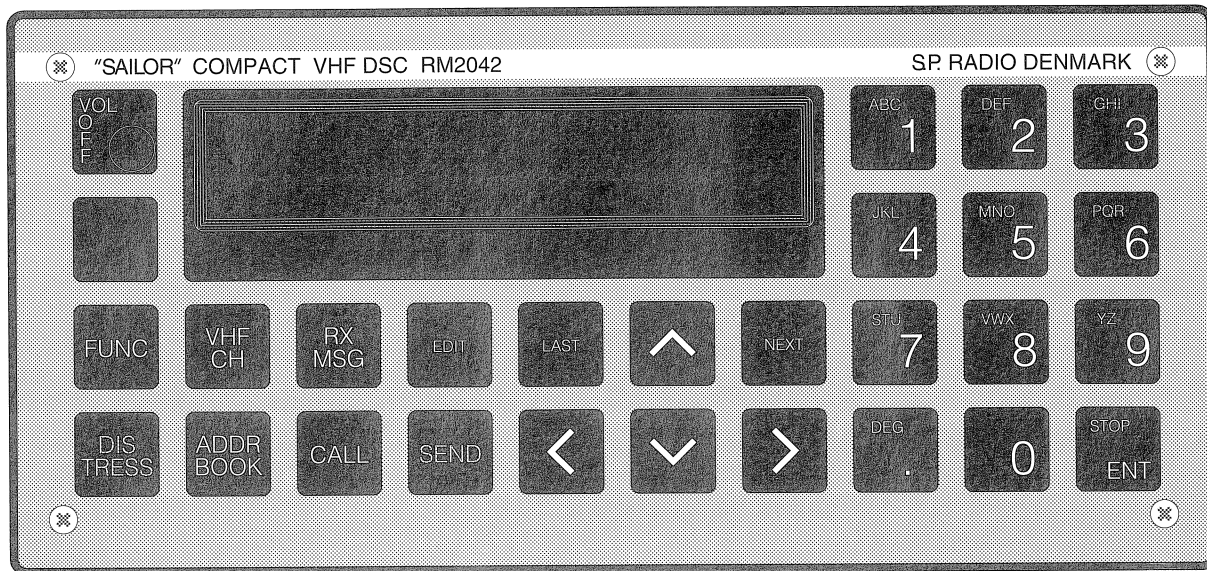

On/off/vol turn-style knob.



Selects the function menu window, from which one of seven different functions can be selected, such as the display control functions, printer function etc.



Activates the VHF channel selection mode, if connected to a VHF transceiver, with serial interface i.e. RT 2048.



Selects the received message menu, which should be used for a display readout of messages in the memory bank.



This button is used when you want to edit the content of a stored, user composed, call sequence, or when you want to edit the position information.



Activated alone, this button is used to enter the distress call menu, in which you can compose your distress message to be transmitted.  
NOTE! Activated simultaneous with the SEND-button, a distress call will be initiated.



Selects the user programmed address book, where you can save up to forty different complete call sequences.



This button is used to enter the call composition menu, where the entry will be either a station name or a MID number. If you press Edit under this menu, the following menus will guide you through the complete composition of a call.



This button is used to initiate a call transmission, when a call has been composed or selected. The unit permits the transmission by an appropriate readout to guide the user.  
NOTE! Activated simultaneous with the DISTRESS-button, a distress call will be initiated.



This button is used to select the next menu in an input sequence, and at the same time the user accepts the content of the actual display read-out.

### 1.3. CONTROLS cont.:



This button is used to step backward, to the last selected menu window in an input sequence.



These buttons are used to scroll between the possible choices in the actual displayed menu. Note that these buttons only will be active, when their signs are shown in the display readout.



These buttons are used to scroll between the input fields in the actual displayed menu window. When an input has been keyed in, and the <-button is pushed the last input will be cleared.



Digits 0 to 9, used for numerical input data to the unit.

These characters will be selected when the user is in a mode where the unit accepts alphabetic characters. At the first activation the first character will be displayed in the actual display input field, at the second activation the second character will be displayed etc. When '>'-button is activated, the displayed character is selected, and the next input field is shown with a blinking readout.



This button is used as a delimiter, when time data or position data are entered from the keyboard.



This key is used to accept the displayed station data in a call composition. When the data has been accepted it will be possible to enter a telephone number, if the entered station is a coast station.

The enter button can also be used to accept entered keyboard inputs, when valid data has been entered in a menu window.



Selects the degree sign in an input sequence for position data.



Stops the build-in alarm circuits, when a distress message has been received.

## 1.4. PRINCIPLE OF OPERATION AND BLOCK DIAGRAM

### RECEIVER

The RF-signal from the antenna is feed to the input amplifier circuit. Here is the initial filtering made by means of a fixed, double tuned filter before the signal is amplified in the front-end amplifier. This amplifier is followed by another fixed, double tuned filter. The amplified and filtered signal is feed to the first mixer stage.

This stage converts the received signal to the first IF frequency on 15.3 MHz. The local oscillator for this stage is created by means of an XTAL oscillator running at 141.225MHz.

The signal is filtered by means of an XTAL-filter, amplified and then feed to the integrated IF-circuit. This circuit includes the second XTAL-oscillator circuit running at 14.85MHz, the second mixer stage and following limiting amplifiers and detector circuits.

The filtering on the second IF-frequency at 450kHz, is made by means of a ceramic filter.

The detected AF-signal is led through an electrical controlled switch, which is only used for loop back test purpose. The output from this switch is filtered in the deemphasis filter, before the AF signal selection, where the selection between the build-in channel-70 receiver and the connected VHF radiotelephone is performed.

The switch setting of the AF selection is determined by the actual operation of the unit and signal strength on Channel-70, giving full priority to the Channel-70 receiver output.

From the connected VHF-radiotelephone, the detected AF-signal is feed to a deemphasis filter and a carrier detect circuit, which provides the needed signals for the demodulator when you are using the public call facilities.

The selected AF-signal is furthermore feed to the interface board, where it is amplified to source an internal loudspeaker.

The FSK-modem performs the demodulation of the received FSK-signal, and the modulation of the AF-signal for the transmitter. The circuit is controlled from the microprocessor board.

Internal power supply for the board, is generated with two regulators, one for 5V and one for 10V.

A power low condition is signaled from the 10V regulator to the microprocessor unit, to secure a controlled power down sequence.

### INTERFACE

This module provides the necessary connections between the modules and between the modules and the externally connected equipment, such as power supply, VHF-transceiver, telephone handset, printer etc. This unit must be supplied with 12V DC, which can be provided either directly from batteries or from N420, 24 to 12V converter. The proper operation of the ON/OFF switch is selected by means of the 12/24V wiring circuit.

Fuse and over/reverse-voltage protection is placed on this module as well.

The 5V power supply for internal digital boards are made on this unit.

The AF power amplifier for the loudspeaker is supplied by its own 5V regulator and the AF comes from the receiver module. Alarm and mute signals are generated on the microprocessor module and feed to the amplifier chain.

Distress channel information for a connected scrambler, is buffered and level shifted, before it is feed to the 9-pole connector.

AF output for the connected transmitter is buffered and level adjusted in different amplifiers.

When the unit is operating in an automatic system with a VHF-transceiver, is the AF output delivered as an unbalanced signal adjusted in level to fit the microphone input sensitivity of the transceiver.

When the unit is operating as a DSC-encoder is the AF output port swiched to supply the signal on a 600 ohm balanced output port. The level can be adjusted to 0dBm  $\pm$ 10dB by means of a trimming potentiometer.

When the VHF port communication switch is set for an automatic system, the serial communication link to the transceiver will be connected to the 9 pole output connector for the VHF.

The remaining circuits on this module consists of input buffers and level shifters for the i/o links to the microprocessor. These links are used for the NMEA interface, printer interface and the interface to C2149, remote distress unit, or a PC for programming or remote control.

## 1.4. PRINCIPLE OF OPERATION AND BLOCK DIAGRAM cont.:

### **MICROPROCESSOR**

The microprocessor module contains as the central unit, the microprocessor IC, a fast 16 bit type, with its external program memory and RAM circuits.

The microprocessor clock-signal is derived from an 8 MHz XTAL-oscillator.

The non-volatile memory consist of a single 8kByte EEPROM, where the received messages and internal programable settings are stored.

As the microcomputer operates with an asynchroneous bus-configuration, some external control logic is needed to generate the appropriate interrupt signals etc. This block includes the reset circuitry as well.

Address selection of the individual peripheral devices is done by means of a 4 to 16 line address decoder.

The answer back from these circuits to the microprocessor, is done via the uP control logic.

The time division on the microprocessor is partially determined by the outputs from the programable timers, and partially by the real time clock circuit.

The real time clock circuit is operating with an external XTAL at 32.768kHz, and has a separate primary battery back-up, to preserve the time settings of the equipment.

The reference clock for the FSK decoder and encoder, is derived from a 4.9152MHz XTAL oscillator, which among others are devided down to a 1200Hz signal.

Communication with the FSK-modem is done via an USART.

The printer interface is made by means of a standard i/o port circuit, placed on the interface module, while the strobe pulse needed for the printer is generated by a few gates on this module.

The serial communication with external equipment, is executed via three USART's placed on the interface module.

An i/o port circuit, is used for the interface between the microprocessor and the different single bit control signals. The same circuit is used when the keyboard matrix are scanned.

This module includes, as well, the +5V to -5V voltage converter, the output of which is used on the display module for the LCD-display.

The voltage for the keyboard light, for night illumination, are also turned on and off on this module.

The switch S1 is used in service.

### **DISPLAY UNIT**

The display unit consist of two circuit boards.

One board connected directly to the microprocessor module. Which includes a D/A converter to control the DC-amplifiers for viewing angel control and display backlight control, and a socket for connection to the display module.

The display is a standard dot-matrix LCD-display module, which includes the necessary drivers and parallel communication circuits.

Power on/off switch and AF-volume potentiometer is mounted on this unit as well.

This unit has been developed to be used in RM2150/51 as well, the identity programming needed is made by means of a jumper on P5.

### **KEYBOARD**

The keyboard module is a standard module for the 2100-series of products. It consist of a 4x7 keybord matrix, and light emitting diodes used for night illumination of the keyboard.

1.4 PRINCIPLE OF OPERATION AND BLOCK DIAGRAM cont.:

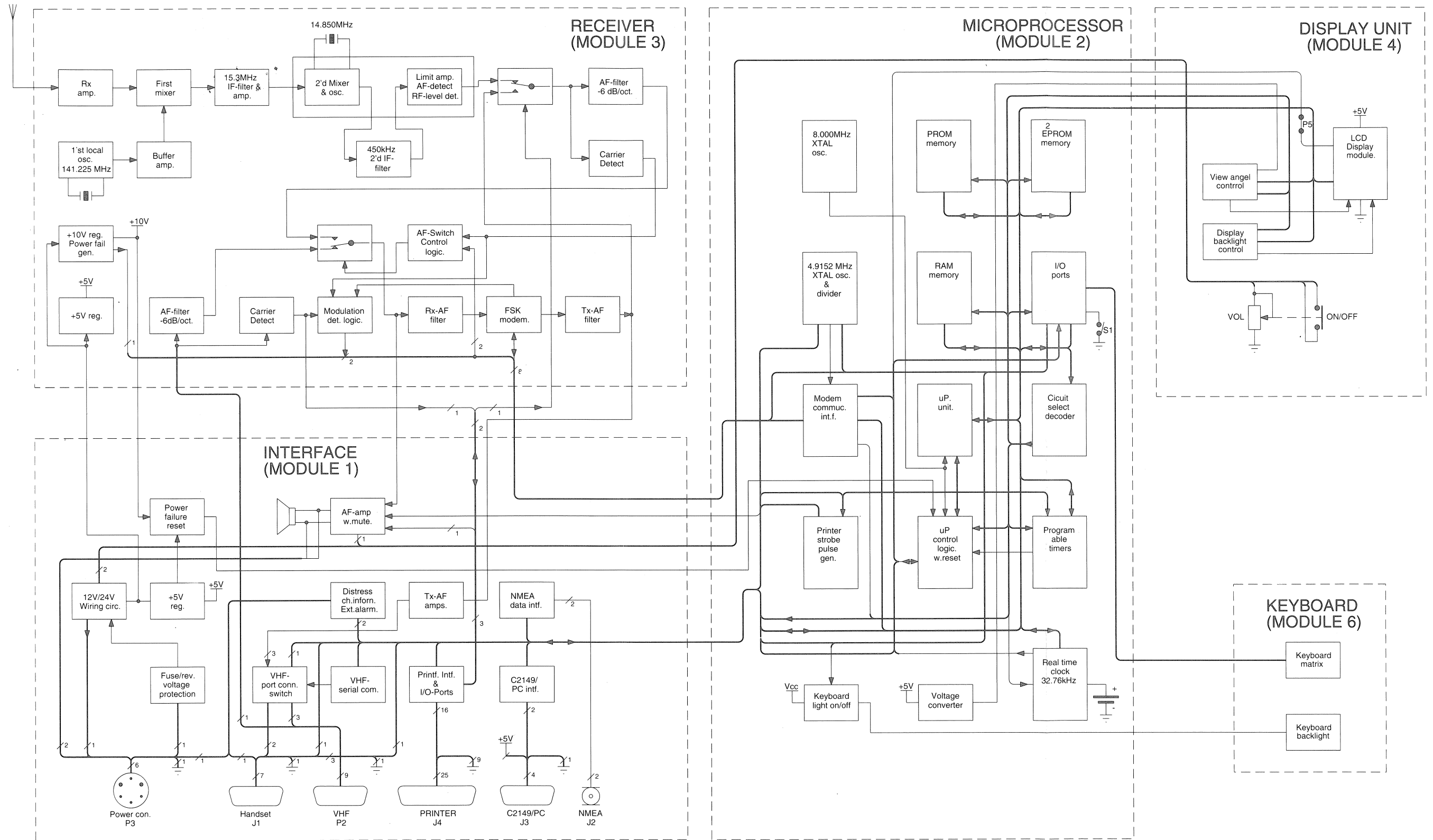

RM2042  
4-0-27502

## CONTENTS

- 2. INSTALLATION
  - 2.1. MOUNTING POSSIBILITIES, DIMENSIONS AND DRILLING PLAN
  - 2.2. POWER SUPPLY
  - 2.3. HANDSET
  - 2.4. ANTENNA
  - 2.5. ELECTRICAL CONNECTIONS



## 2. INSTALLATION

### 2.1. MOUNTING POSSIBILITIES, DIMENSIONS AND DRILLING PLAN

The VHF DSC RM2042 cabinet is designed in a module called a mini 1/4 box. For this module we can supply a wide variety of installation brackets etc. which will be described below. We have made a drawing including dimensions and drilling plan for each type and we kindly ask you to look at the drawing for the type in question.

#### VHF DSC RM2042 AND VHF RT2048 MOUNTED ON TOP OF EACH OTHER USING H2067 MOUNTING BRACKET FOR TABLETOP, BULKHEAD OR DECKHEAD FOR MINI 1/4 BOX AND H2072 LASHING KIT.

This mounting bracket H2067 and lashing kit H2072 is used when RM2042 is to be mounted on top of each other and next to other units in the Compact 2000 programme mounted in H2055 mounting brackets.

#### H2072

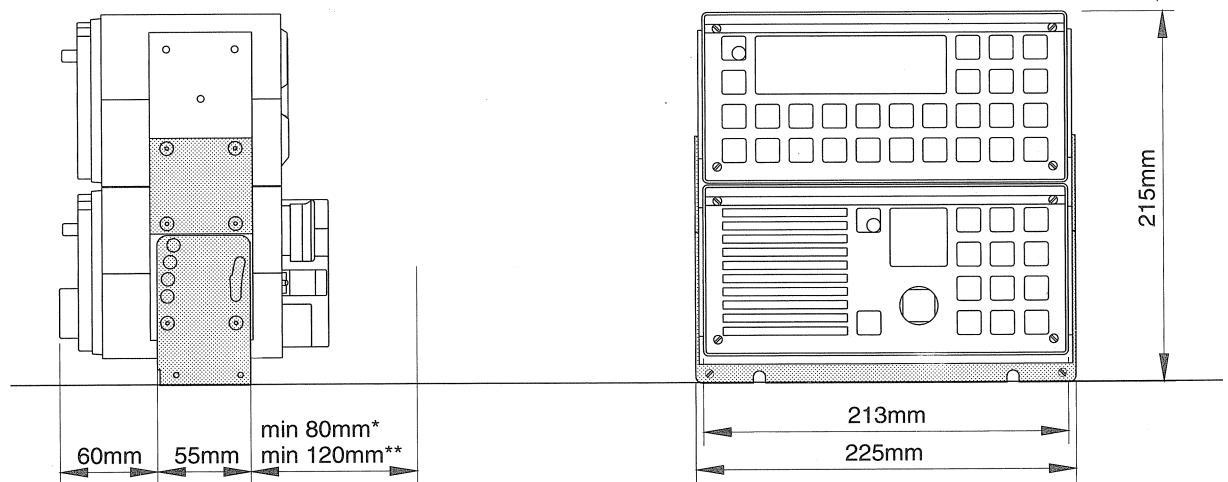

\* dimensions when using a right-angled VHF plug

\*\* dimensions when using a standard VHF plug

#### Weight:

Mounting kit H2067:	0.5 kg
Mounting kit H2072:	0.1 kg
VHF RT2048:	3.2 kg
VHF DSC RM2042:	2.0 kg

2.1. MOUNTING POSSIBILITIES, DIMENSIONS AND DRILLING PLAN cont.:

**H2067 MOUNTING BRACKET FOR TABLETOP, BULKHEAD OR DECKHEAD MOUNTING FOR MINI 1/4 BOX**

This mounting bracket is used when RM2042 is to be mounted next to other units in the Compact 2000 programme mounted in H2055 mounting brackets. For example when installing the RM2042 next to the HF SSB RE2100 it is possible to tilt both units in the same angle.

**H2067**

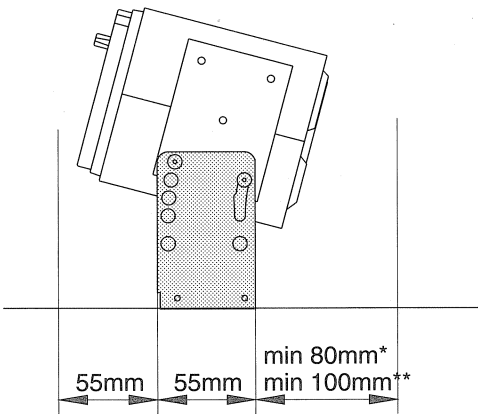
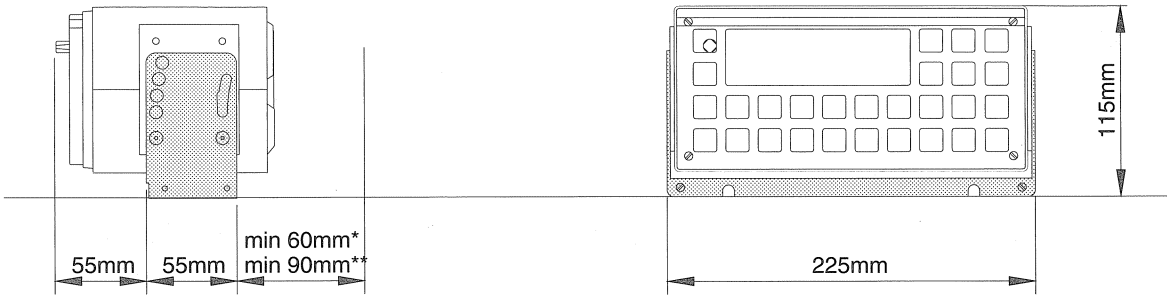

\* dimensions when using a right-angled VHF plug  
 \*\* dimensions when using a standard VHF plug

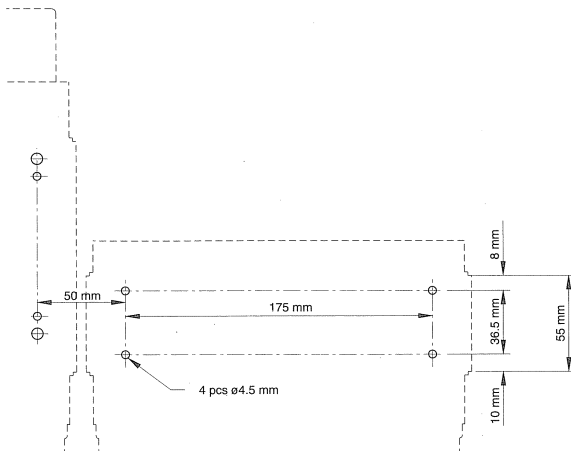

Weight:  
 Mounting kit H2067: 0.5 kg  
 VHF DSC RM2042: 2.0 kg

RM2042  
 4-0-27582 4-0-27593  
 4-0-27566

2.1. MOUNTING POSSIBILITIES, DIMENSIONS AND DRILLING PLAN cont.:

**H2057 ANGLE HINGES FOR TABLETOP, BULKHEAD OR DECKHEAD MOUNTING FOR MINI 1/4 BOX**

H2057 is designed for stationary installation. It offers a lot of mounting possibilities using the different holes in the angle hinges when tilting the VHF DSC.

**H2057**

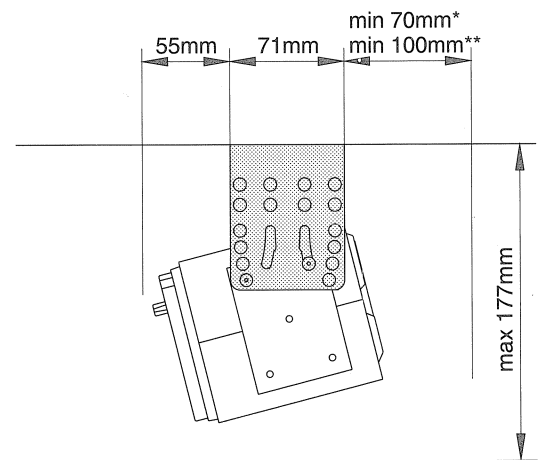
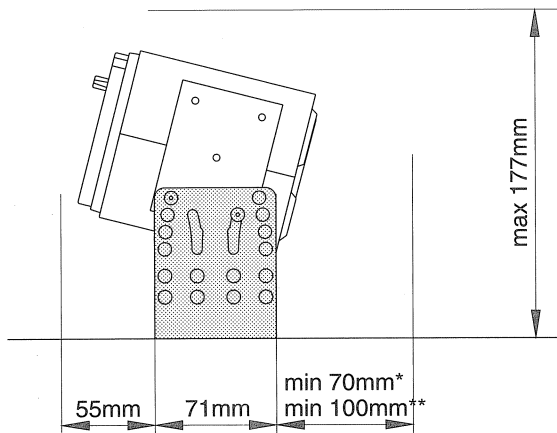
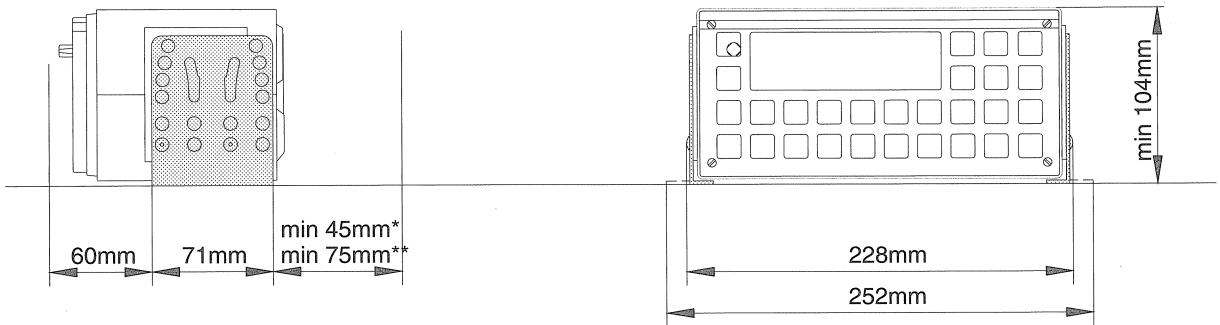

\* dimensions when using a right-angled VHF plug  
 \*\* dimensions when using a standard VHF plug

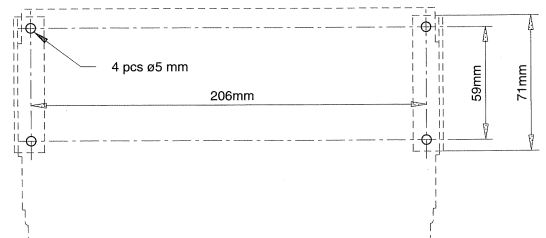
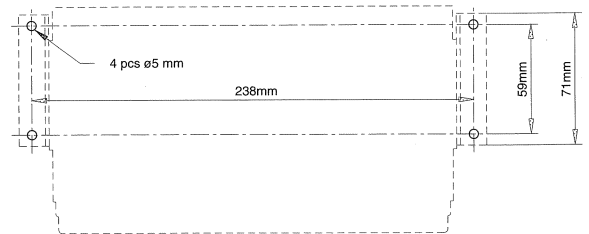
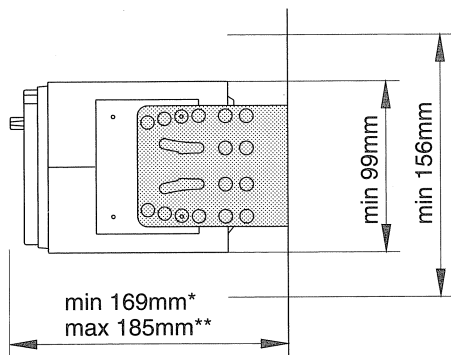

RM2042  
 4-0-27594-597  
 4-0-27574-575

Weight:  
 Mounting kit H2057: 0.4 kg  
 VHF DSC RM2042: 2.0 kg

## 2.1. MOUNTING POSSIBILITIES, DIMENSIONS AND DRILLING PLAN cont.:

### H2063 CONSOLE MOUNTING KIT FOR 1/4 BOX

This mounting kit is used for console flush mounting of 1/4 box and mini 1/4 box.  
Free distance must be kept to allow free air circulation, ambient temperature max. 40°C.

### H2063

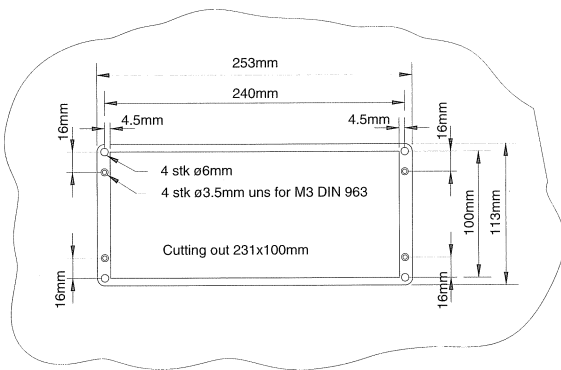
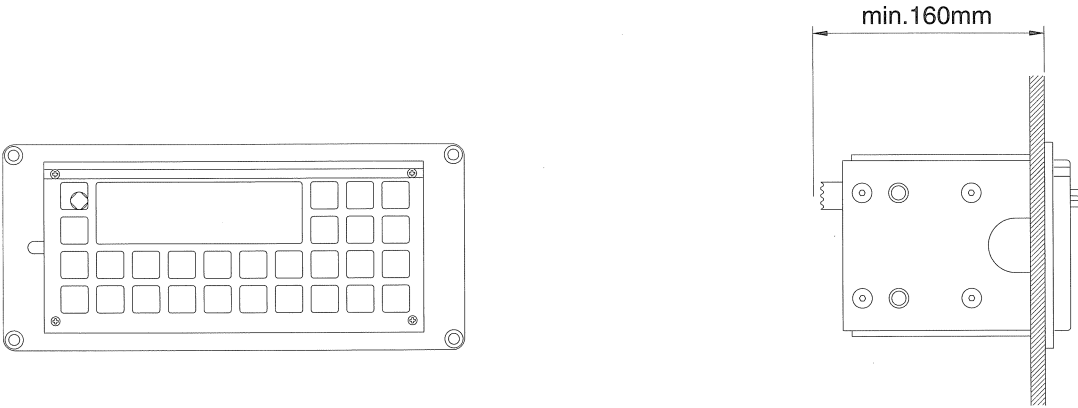

Weight:  
Mounting kit H2063: 1.0 kg  
VHF DSC RM2042: 2.0 kg

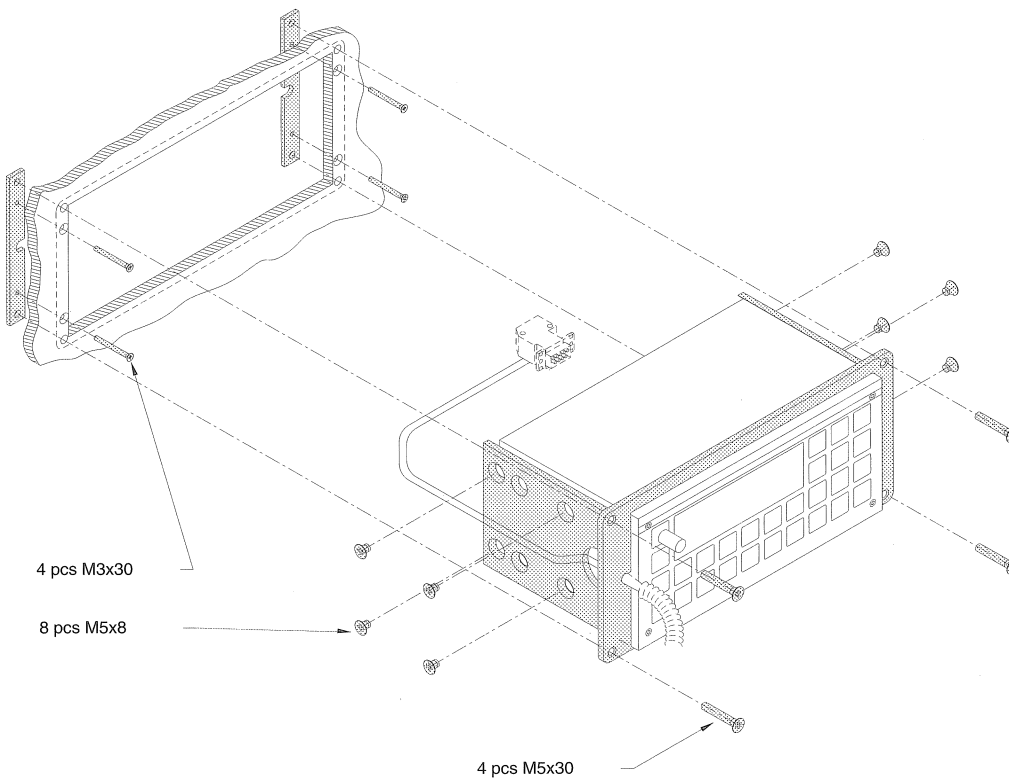

RM2042  
4-0-27580 4-0-27444  
4-0-27581

## 2.2. POWER SUPPLY

The standard power supply for the VHF DSC unit RM2042 is 12V DC.

For 24V DC supply an external power supply with the type number N420 can be used. The N420 is in principle a 24V DC to 13.2V DC serial regulator.

For 110V AC, 127V AC, 220V AC or 237V AC operation, an external power supply with the type number N163S must be used together with N420.

## 2.3. HANDSET

The handset is normally connected directly to the VHF radiotelephone, but in a VHF DSC installation with the RM2042, the handset must be connected to this unit instead.

The handset can be placed anywhere near the VHF DSC unit RM2042.

The cable for the handset is five-cored and must be connected to the rear of RM2042 by means of the 9 pole SUB-D connector J1-1.

For installation of the cable, please see the drawings of the mounting brackets. The cable grommet must be placed in the most convenient groove in the mounting bracket.

If more than one handset is needed, please see section 6, SPECIAL INSTALLATION WITH 2 OR 3 MICROTELEPHONES.

## 2.4. ANTENNA

All common 50Ω antennas, which cover the used frequency range with a reasonable standing wave ratio, maximum 1.5, are usable.

The antenna is connected to the set by means of a 50Ω coaxial cable with low loss, e.g. RG213U. At the cable end a PL259 plug is mounted.

The antenna must be placed as high and clear as possible. The horizontal distance to metal parts must be at least one metre.

S. P. Radio has an antenna with the necessary specifications available. The mentioned antenna is characterized by small external dimensions. For further details, see the special brochure VHF AERIALS.

12V OPERATION

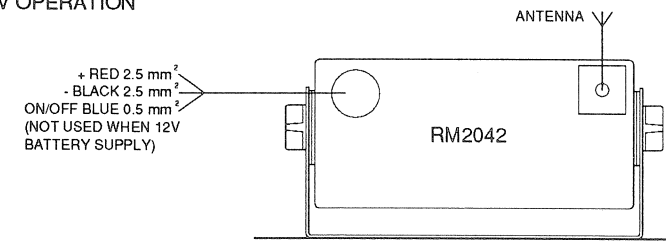

BLOCK DIAGRAM OF STRAPPING FOR 12V DC

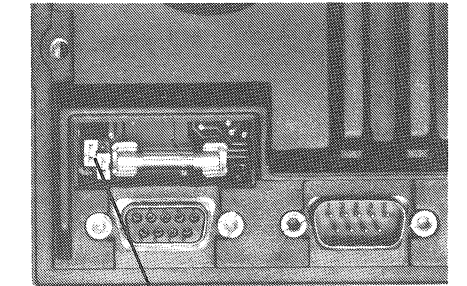
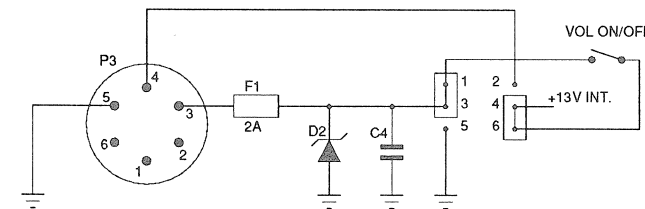

Strap for connection to external supply (12V)

24V OPERATION

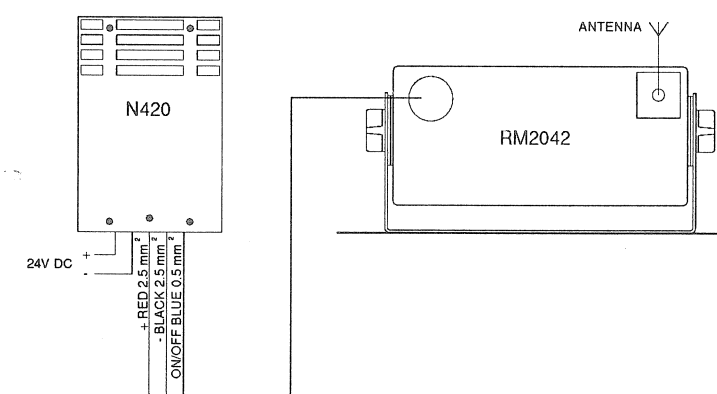

BLOCK DIAGRAM OF STRAPPING FOR 24V DC

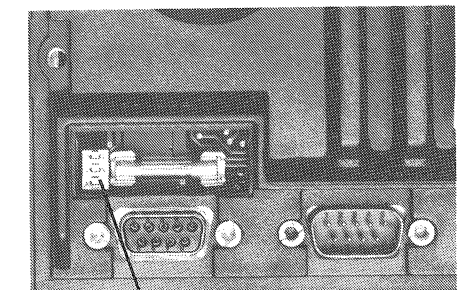
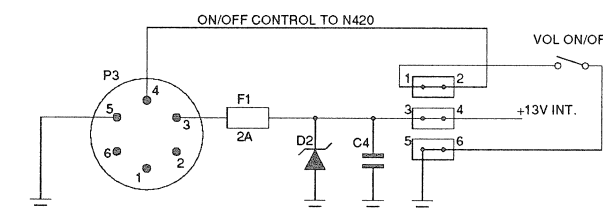

Strap for connection to N420 (24V)

## 2.5. ELECTRICAL CONNECTIONS

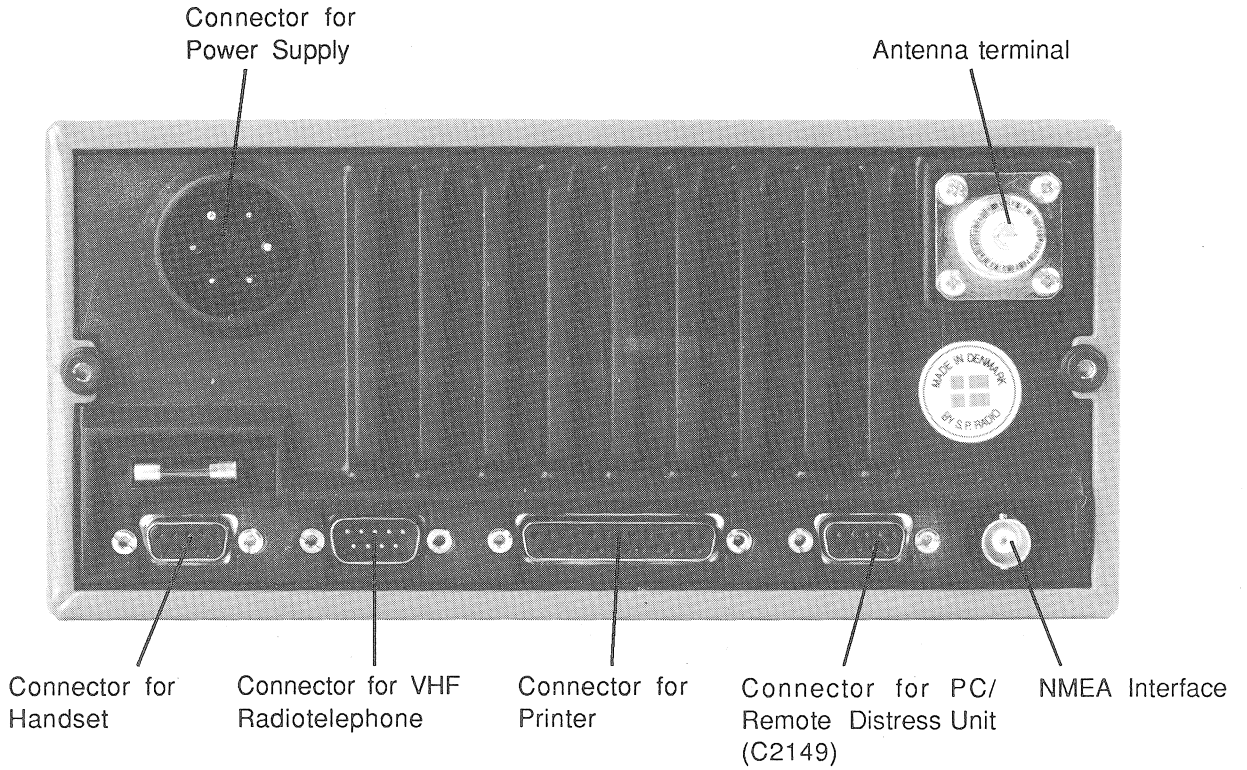

RM2042  
501224  
4-0-27772 4-0-27773

POWER CONNECTOR

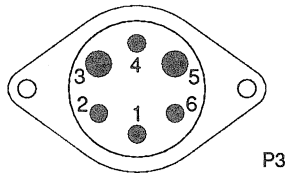

PIN 1	EXT. LOUDSPEAKER
PIN 2	REMOTE AL. CIRC.
PIN 3	+ BATTERY
PIN 4	EXT. SUPPLY ON/OFF
PIN 5	- BATTERY
PIN 6	EXT. LOUDSPEAKER

CONNECTOR FOR HANDSET

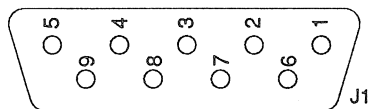

PIN 1	TELEPHONE
PIN 2	GND
PIN 3	MIC.GND
PIN 4	MIC.
PIN 5	KEY
PIN 6	
PIN 7	DISTRESS
PIN 8	
PIN 9	+12V FROM VHF



2.5. ELECTRICAL CONNECTIONS cont.:

CONNECTOR FOR VHF

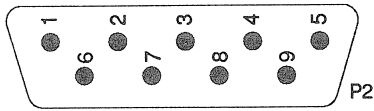

- PIN 1 TELEPHONE
- PIN 2 GND
- PIN 3 MIC.GND
- PIN 4 MIC./TX AF +
- PIN 5 KEY
- PIN 6 RX AF FROM VHF
- PIN 7 DISTRESS / BUS INTERRUPT
- PIN 8 DATA/TX AF -
- PIN 9 +12V FROM VHF

CONNECTOR FOR PRINTER

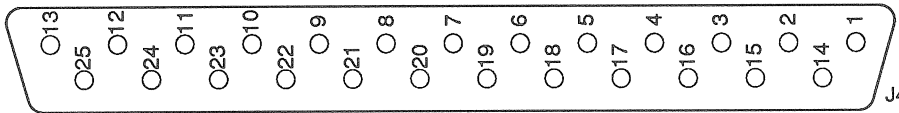

- PIN 1 STROBE
- PIN 2 D0
- PIN 3 D1
- PIN 4 D2
- PIN 5 D3
- PIN 6 D4
- PIN 7 D5
- PIN 8 D6
- PIN 9 D7
- PIN 10 ACKN
- PIN 11 BUSY
- PIN 12 PE
- PIN 13 SELECT

- PIN 14 AUT FEED
- PIN 15 ERROR
- PIN 16 INIT
- PIN 17 SLCT IN
- PIN 18 GND
- PIN 19 GND
- PIN 20 GND
- PIN 21 GND
- PIN 22 GND
- PIN 23 GND
- PIN 24 GND
- PIN 25 GND

CONNECTOR FOR  
PC/REMOTE DISTRESS UNIT

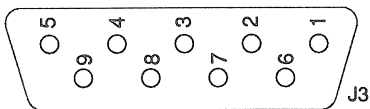

- PIN 1
- PIN 2 RS232 INPUT
- PIN 3 RS232 OUTPUT
- PIN 4
- PIN 5 GND
- PIN 6
- PIN 7
- PIN 8
- PIN 9 DISTRESS UNIT SUPPLY

## CONTENTS

- 3. SERVICE
  - 3.1. MAINTENANCE
  - 3.2. ALIGNMENT INSTRUCTIONS
  - 3.3. PROPOSAL FOR NECESSARY TEST EQUIPMENT
  - 3.4. TROUBLE SHOOTING
  - 3.5. PERFORMANCE CHECK
  - 3.6. ADJUSTMENT PROCEDURE
    - 3.6.1. ADJUSTMENT OF INTERFACE (MODULE 1)
    - 3.6.2. ADJUSTMENT OF MICROPROCESSOR (MODULE 2)
    - 3.6.3. ADJUSTMENT OF RECEIVER (MODULE 3)
  - 3.7. REPLACEMENT OF COMPONENTS
  - 3.8. REPLACEMENT OF MODULES
  - 3.9. NECESSARY ADJUSTMENTS AFTER REPAIR
    - 3.9.1. REPAIR/REPLACEMENT OF INTERFACE (MODULE 1)
    - 3.9.2. REPAIR/REPLACEMENT OF MICROPROCESSOR (MODULE 2)
    - 3.9.3. REPAIR/REPLACEMENT OF RECEIVER (MODULE 3)
  - 3.10. PIN CONFIGURATIONS

## 3. SERVICE

### 3.1. MAINTENANCE

#### PREVENTIVE MAINTENANCE

If the VHF DSC RM2042 has been installed in a proper way the maintenance can, dependent on the environments and working hours, be reduced to a performance check at the service workshop at intervals, not exceeding 12 months. A complete performance check list is enclosed in this manual, chapter 3.5 PERFORMANCE CHECK.

Inspection of the antenna, cables, and plugs for mechanical defects, salt deposits, corrosion, and any foreign bodies shall be done at regular intervals not exceeding 12 months.

Along with each RM2042 a test sheet is delivered in which all the measurements, made in the test department of the factory, are listed. If the control measurements made in the service workshop should not show the same values as those listed in the test sheet, the set must be adjusted as specified in chapter 3.6. ADJUSTMENT PROCEDURE.

#### CHANGE OF BATTERY FOR BACK-UP

The RM2042 is constructed with a real time clock, which uses a lithium battery for power back-up. By means of this battery, it is possible to maintain track of time and date even though the RM2042 has been turned off.

The capacitance of the battery is 360 mAh (milli Ampere hours) and as the real time clock only consumes a current of about  $7\mu\text{A}$ , the battery should last for a period of at least five years. However, in practice this period may be longer, because the battery is only used when the RM2042 is turned off.

The battery is located at the microprocessor (module 2) and is soldered to the PCB to obtain mechanical stability.

The battery can be ordered from S.P. Radio, Denmark by using the spare part number 47.004.

**IMPORTEN!** The old battery shall be handed over to the authorities for proper destruction, to avoid damages of the enviromental by the lithium.

#### CHANGE OF SOFTWARE

The microprocessor (module 2) includes the two PROM's U3 and U5, which contain the software. To locate these PROM's please see the photo of the microprocessor module given in section 4 in this manual.

**NOTE!** If the software has to be changed, it is always necessary to change both PROM's at a time.

### 3.2. ALIGNMENT INSTRUCTIONS

#### INTRODUCTION

The measuring values indicated in chapter 5. CIRCUIT DESCRIPTION AND SCHEMATIC DIAGRAMS are typical values and as indicated it will be necessary to use instruments in absolute conformity with the list given on the next page.

### 3.3. PROPOSAL FOR NECESSARY TEST EQUIPMENT

#### OSCILLOSCOPE:

Bandwidth	DC-35 MHz
Sensitivity	2mV/div
Input Impedance	1 Mohm/20 pF
E.g. Philips type	PM3050

#### PASSIVE PROBE:

Attenuation	20 dB
Input Impedance	10 Mohm//15 pF
Compensation Range	10-30 pF
E.g. Philips type	PM8936/091

#### MULTIMETER:

Sensitivity DC (f.s.d.)	100 mV
Input Impedance	10 Mohm
Accuracy DC (f.s.d.)	1.5%
E.g. Philips type	PM2505

#### FREQUENCY COUNTER:

Frequency Range	100 Hz - 165 MHz
Resolution	1 Hz at f = 100 MHz
Accuracy	$1 \times 10^{-7}$
Sensitivity	100 mV RMS
Input Impedance	1 Mohm/30 pF
E.g. Philips type	PM 6674

#### RF SIGNAL GENERATOR:

Frequency Range	155 MHz - 165 MHz
Output Level:	-124dBm - +7dBm (EMF: $0.25 \mu V_{RMS}$ - $1 V_{RMS}$ )
Output Impedance	50 ohm
Type of Modulation	FM
Modulation Frequency	External: 1.3kHz, 2.1kHz / Internal: 1kHz
E.g. Rohde & Schwarz	CMT

#### RF MODULATION METER:

Frequency Range	155 MHz - 165 MHz
Input Impedance	50 ohm
E.g. Rohde & Schwarz	CMT

#### LF SIGNAL GENERATOR:

Frequency Range	100 Hz - 3 kHz
Output Level	10 mV - 1V
Output Impedance	50 ohm
E.g. Hewlett-Packard	HP 8903B

#### LF DISTORTION METER:

Frequency Range	1000 Hz, 1300 Hz, 2100 Hz
Distortion Range (f.s.d.)	0.1-10%
Input Impedance	100 kohm
Accuracy (f.s.d.)	5% of reading
E.g. Hewlett-Packard	HP 8903B

### 3.4. TROUBLE SHOOTING

Trouble shooting should only be performed by persons with sufficient technical knowledge, who have the necessary measuring instruments at their disposal, and who have carefully studied the operation principles and structure of the VHF DSC RM2042.

The first thing to check is whether the fault is somewhere in the antenna circuit, the power source, the handset, or inside the RM2042 itself.

In order to help you during trouble shooting, the section 5. CIRCUIT DESCRIPTION AND SCHEMATIC DIAGRAMS contains diagrams, principal descriptions, and drawings showing the location of the individual components. Typical values for the DC and AC voltages are indicated in the diagrams, and also the test points are indicated in the diagrams.

The RM2042 has a number of trimming cores and trimmers, which must not be touched unless adjustments as specified in section 3.6. ADJUSTMENT PROCEDURE can be made.

When measuring inside the unit, short circuits must be avoided as the transistors would then be spoiled.

## 3.5. PERFORMANCE CHECK

### CHECK OF SYSTEM PERFORMANCE.

With this check procedure it is possible to control the performance of a whole VHF DSC system, which include the DSC unit it self, the VHF transceiver, a GPS receiver and a printer.

The idea of this test procedure is first to key-in a call sequence and hereby control the connections to the key board and display, and the function of these modules. The next step is to send the DSC call to your self, which is done in the 'CALL' menu by keying-in the MID-number of the unit it self. The DSC call is now generated by the microprocessor and the FSK encoder at the receiver module. The FSK signal is then modulating the connected VHF radiotelephone and a short piece of wire connected to the antenna terminal at the VHF will be sufficient to transfer the RF-signal to the channel-70 receiver. The received signal is then demodulated, decoded, sampled and finally recognized by the microprocessor. As a response to the reception of the call, the microprocessor will write the received message to the printer and at the same time generate a gated tone sequence for the internal loudspeaker.

The primary force of this test is that the function of all modules is controlled and that the connections for external equipment are checked as well. An other force is the fact that the test procedure does not require any test equipment.

The check procedure can also be used as a function check after the system has been installed.

- 1: Connect the RM2042 to the VHF transceiver, the printer and the GPS receiver (if available)
- 2: Select the 'FUNC' menu and then the 'Position' menu. Control that the position data is updated by the GPS receiver.
- 3: Select the 'CALL' menu and press the 'up-arrow' button to key-in the MID-number of the DSC unit it self.
- 4: Press 'NEXT' and select 'Position' by means of the 'left-arrow' and the 'NEXT' button.
- 5: Press 'NEXT' and 'SEND' for transmission of the DSC call.
- 6: The DSC call should now be received by the RM2042 and the alarm signal will be heard in the internal loudspeaker. The RM2042 will write the received message to the printer.

### CHECK OF RECEIVER SENSITIVITY.

The receiver sensitivity is controlled by applying a RF-signal to the antenna terminal and then measuring the output signal-to-noise ratio (SND/N) by means of a voltmeter.

- 1: Connect a RF-signal generator to the antenna input and adjust the carrier level to -119 dBm (EMF: -6 dB/ $\mu$ V). Modulate the carrier with 1 kHz to a peak frequency deviation of 3 kHz.
- 2: Connect a voltmeter to the analog switch output, pin 14 at U6-3, for measuring the AC-voltage.
- 3: Read the meter deflection by means of the dB scale.
- 4: Remove the modulation and control that the output level decrease more than 12 dB.



### 3.5. PERFORMANCE CHECK cont.:

#### CHECK OF RECEIVER DISTORTION.

The receiver distortion is controlled by applying a RF-signal to the antenna terminal and then measuring the output distortion by means of a distortion meter.

- 1: Connect a RF-signal generator to the antenna input and adjust the carrier level to -30 dBm (EMF: 83 dB/ $\mu$ V). Modulate the carrier with 1 kHz to a peak frequency deviation of 3 kHz.
- 2: Connect a distortion meter to the analog switch output, pin 14 at U6-3, for measuring the receiver distortion.
- 3: The measured distortion shall be less than 3%.

#### CHECK OF DSC CALL SENSITIVITY.

The DSC call sensitivity is controlled by modulating a RF-signal generator with a DSC call, which is generated by the DSC unit it self.

NOTE! To perform this test, it is necessary to change the operation mode of the RM2042 from user to service mode. This change of operation mode is only allowed for trained technicians and the information of how to do it, is therefore only included in the DSC-VHF INSTALLATION GUIDE.

- 1: Select the balanced TX AF amplifier as interface to the RF-signal generator, by turning the switch S1-1 at the interface module into the position: 'E'.
- 2: Connect the output of the balanced TX AF amplifier to the external modulation input of the RF-signal generator. Use pin 4 (TX AF+) and pin 8 (TX AF-) in the 9 pole SUB-D connector P2 (connector for VHF transceiver).
- 3: Connect the output of the RF-signal generator to the antenna terminal of the RM2042.
- 4: Apply an external modulated carrier with the frequency 156.525 MHz to the antenna terminal and adjust the output level to -113 dBm (EMF: 0 dB/ $\mu$ V).
- 5: Change the operation mode of the RM2042 from user to service mode.
- 6: Select the 'FUNC' menu and then the 'Test' menu. Select 'Dot pattern' by means of the 'left-arrow' or 'right-arrow', and press the 'NEXT' button.
- 7: Adjust the peak deviation at the RF-signal generator to 3400 Hz and press the 'STOP/ENT' button to terminate the transmission of dot pattern.
- 8: Select 'Test call' by means of the 'left-arrow' or 'right-arrow' and press 'NEXT' to start the continuous transmission of a test call to the unit it self.
- 9: Now control that the RM2042 is receiving a continuous sequence of individual calls.
- 10: Terminate this procedure by turning the RM2042 off. Remember to change the operation mode back to user mode.

### 3.5. PERFORMANCE CHECK cont.:

#### CHECK OF RX AF FILTER RESPONSE.

The response of the RX AF filter is essential for the bit error rate and must therefore be checked carefully.

- 1: Disconnect any input to the antenna terminal.
- 2: Connect a LF-signal generator to pin 6 (RX AF FROM VHF) and pin 2 (GND) in the 9 pole SUB-D connector P2-1 at the interface module.
- 3: Connect a voltmeter to the output of the RX AF filter for measuring the AC voltage (U8.4-3, pin 14).
- 4: Adjust the frequency of the LF-signal generator to 1700 Hz and the output level to  $350 \text{ mV}_{\text{RMS}}$ .
- 5: Measure the output level, which shall be  $220 \text{ mV}_{\text{RMS}} \pm 30 \text{ mV}$ . The measured value is used as reference in the following measurements.
- 6: Change the input frequency to 1300 Hz and control that the output level increase with 1 dB  $\pm 0.5$  dB.
- 7: Change the input frequency to 2100 Hz and control that the output level decrease with 2 dB  $\pm 0.5$  dB with reference to the value measured in point 5.
- 8: Change the input frequency to 650 Hz and control that the output level decrease by more than 20 dB with reference to the value measured in point 5.
- 9: Change the input frequency to 3000 Hz and control that the output level decrease by more than 20 dB with reference to the value measured in point 5.

#### CHECK OF TX AF LEVEL.

The TX AF level is controlled by checking that the peak deviation of the transmitted RF-signal is correct. NOTE! To perform this test, it is necessary to change the operation mode of both the RM2042 and the VHF transceiver from user to service mode. This change of operation mode is only allowed for trained technicians and the information of how to do it is therefore only included in the DSC-VHF INSTALLATION GUIDE.

- 1: Connect the RM2042 to the VHF transceiver by means of the 9 pole SUB-D connector P2-1 at the interface module.
- 2: Reduce the output RF-power from the VHF transceiver to 1 Watt.
- 3: Connect a modulation meter through an attenuator to the antenna terminal at the VHF transceiver.  
NOTE ! To protect the modulation meter from damages caused by the large output voltage, it is necessary to use an attenuator of about 30dB.
- 4: Change the operation mode of the RT2047 or the RT2048 from user to service mode. Select a DSC VHF channel different from channel 70 and change the operation mode back to user mode.
- 5: Change the operation mode of the RM2042 from user to service mode.
- 6: Start the transmission of a mark signal by pressing 'FUNC' and selecting 'Test' and 'mark' in the display.
- 7: Control that the peak frequency deviation is  $2600 \text{ Hz} \pm 10\%$ .

### 3.5. PERFORMANCE CHECK cont.:

- 8: Start the transmission of a space signal.
- 9: Control that the peak frequency deviation is 4200 Hz  $\pm$ 10%.
- 10: Change the operation mode of the RM2042 back to user mode.
- 11: Change the DSC VHF channel setting back to channel 70.

#### CHECK OF TX AF DISTORTION.

The TX AF distortion is controlled by measuring the distortion of the TX AF signal at pin 4 in the 9 pole SUB-D connector P2-1 at the interface module.

NOTE! To perform this test, it is necessary to change the operation mode of the RM2042 from user to service mode. This change of operation mode is only allowed for trained technicians and the information of how to do it is therefore only included in the DSC-VHF INSTALLATION GUIDE.

- 1: Connect a LF-distortion meter to the output of the used TX AF amplifier.  
Unbalanced TX AF amplifier: use pin 4 (TX AF+) and pin 2 (GND) in P2-1.  
Balanced TX AF amplifier: use pin 4 (TX AF+) and pin 8 (TX AF-) in P2-1.
- 2: Change the operation mode of the RM2042 from user to service mode.
- 3: Start the transmission of a mark signal by pressing 'FUNC' and selecting 'Test' and 'mark' in the display.
- 4: Control that the distortion is less than 5%.
- 5: Start the transmission of a space signal.
- 6: Control that the distortion is less than 5%.
- 7: Change the operation mode of the RM2042 back to user mode.

## 3.6. ADJUSTMENT PROCEDURE

This section contains the adjustment procedures for all adjustable components in the RM2042.

### 3.6.1. ADJUSTMENT OF INTERFACE (MODULE 1)

#### ADJUSTMENT OF UNBALANCED TX AF AMPLIFIER

When the RM2042 is operating as an automatic system together with one of our VHF transceiver, the TX AF output is delivered as an unbalanced signal adjusted in level to give a modulation index of 2, measured at the transmitter output. During the adjustment, the RM2042 must be connected to the same VHF transceiver as it is going to be installed with. This demand is motivated by the fact, that the microphone input sensitivity may vary from one transceiver to an other.

The unbalanced signal is amplified by the operational amplifier U3.3 and the output level is adjusted by means of the trimpot R22-1.

**NOTE!** To perform this test, it is necessary to change the operation mode of the RM2042 and the VHF transceiver from user to service mode. This change of operation mode is only allowed for trained technicians and the information of how to do it is therefore only included in the DSC-VHF INSTALLATION GUIDE.

- 1: Connect the RM2042 to the VHF transceiver by means of the 9 pole SUB-D connector P2-1 at the interface module.
- 2: Reduce the output RF-power from the VHF transceiver to 1 Watt.
- 3: Connect a modulation meter through an attenuator to the antennae terminal at the VHF transceiver.  
**NOTE !** To protect the modulation meter from damages caused by the large output voltage, it is necessary to use an attenuator of about 30dB.
- 4: Change the operation mode of the RT2047 or the RT2048 from user to service mode. Select a DSC VHF channel different from channel 70 and change the operation mode back to user mode.
- 5: Change the operation mode of the RM2042 from user to service mode.
- 6: Turn the switch S1-1 at the interface (module 1) into the position: '1'.
- 7: Start the transmission of a mark signal by pressing 'FUNC' and selecting 'Test' and 'mark' in the display.
- 8: Adjust R22 until the peak frequency deviation is 2600 Hz  $\pm$ 10%.
- 9: Start the transmission of a space signal.
- 10: Control that the peak frequency deviation is 4200 Hz  $\pm$ 10%.
- 11: Change the operation mode of the RM2042 back to user mode.
- 12: Change the DSC VHF channel setting back to channel 70.

### 3.6.1. ADJUSTMENT OF INTERFACE (MODULE 1) cont.:

#### ADJUSTMENT OF BALANCED TX AF AMPLIFIER

When the RM2042 is used as an encoder in a semi automatic system, the balanced TX AF output has to be used. The balanced amplifier is build-up around the operational amplifier U3.2-1, the transistor Q4-1 and the transformer TR1-1. The output level is adjustable to 0 dBm  $\pm$ 10 dB by means of the trimpot R17-1 and must be adjusted in order to give a modulation index of 2  $\pm$ 10%. As mentioned in the previous adjustment procedure, it is necessary to use the same VHF transceiver during the adjustment as the one the RM2042 is going to be installed with.

NOTE! To perform this test, it is necessary to change the operation mode of both the RM2042 and the VHF transceiver from user to service mode. This change of operation mode is only allowed for trained technicians and the information of how to do it is therefore only included in the DSC-VHF INSTALLATION GUIDE.

- 1: Repeat point 1 - 5 in the previous adjustment procedure.
- 2: Turn the switch S1-1 into the position: 'E'.
- 3: Start the transmission of a mark signal by pressing 'FUNC' and selecting 'Test' and 'mark' in the display.
- 4: Adjust R17 until the peak frequency deviation is 2600 Hz  $\pm$ 10%.
- 5: Repeat point 9, 10 and 11 in the previous adjustment procedure.

### 3.6.2. ADJUSTMENT OF MICROPROCESSOR (MODULE 2)

#### ADJUSTMENT OF 4.9152 MHz OSCILLATOR

The 4.9152 MHz oscillator is build-up around the inverter U16.4-2 as a gate oscillator and is adjusted by the trimming capacitor C45-2. The oscillator is used for baud rate generation and must therefore be adjusted carefully.

- 1: Connect a frequency counter by means of a passive probe to the output CT0 (pin 9) of the counter U20-2.
- 2: Adjust C45-2 until the frequency is 2.4576 MHz  $\pm$ 2 Hz.

#### ADJUSTMENT OF 32.768 kHz OSCILLATOR

The 32.768 kHz oscillator is build-up around U31-2 and is adjusted by the trimmer capacitor C39-2. The oscillator is used for real time clock generation and must therefore be adjusted carefully.

- 1: Connect a frequency counter by means of a passive probe to the MFO output (pin 16) of the integrated real time clock circuit.
- 2: Adjust C39-2 until the frequency is 32.768 kHz  $\pm$ 1 Hz.

### 3.6.3. ADJUSTMENT OF RECEIVER (MODULE 3)

#### ADJUSTMENT OF FIRST LOCAL OSCILLATOR

The 1st. local oscillator is adjusted by the coil L6-3.

- 1: Connect a frequency counter by means of a passive probe to the tap of the two capacitors C89-3 and C90-3.
- 2: Adjust the coil L6-3 by a plastic or ceramic stick until the frequency is  $141.225 \text{ MHz} \pm 100 \text{ Hz}$ .

#### ADJUSTMENT OF SECOND LOCAL OSCILLATOR

The 2nd. local oscillator is partly build into the integreted IF circuit and is adjusted by the external trimmer capacitor C34-3. The oscillator is adjusted by measuring the frequency of the down converted signal at the 2nd. IF = 450 kHz.

- 1: Apply an unmodulated carrier with the frequency 156.525 MHz to the antenna terminal and adjust the output level of the RF-signal generator to 0 dBm (EMF:  $113 \text{ dB}/\mu\text{V}$ ).
- 2: Connect a frequency counter by means of a passive probe to the limiter output (pin 7) at U1-3.
- 3: Adjust C34-3 until the frequency is  $450 \text{ kHz} \pm 25 \text{ Hz}$ .  
NOTE! Be careful not to press the trimming capacitor, while the adjustment is performed. The trimming capacitor is constructed with a ceramic plate and is therefore easily damage by pressure.

#### ADJUSTMENT OF FRONT-END FILTERS AND MIXER TRANSFORMERS

The front-end filters contains four adjustable coils and the mixer includes two adjustable transformers. All components are adjusted to maximum meter deflection at the field stregh meter output and the mixer output transformer TR2-3 is afterwards adjusted to minimum distortion.

- 1: Apply an unmodulated carrier with the frequency 156.525 MHz to the antenna terminal and adjust the output level to -80 dBm (EMF:  $33 \text{ dB}/\mu\text{V}$ ).
- 2: Connect a multimeter to the field strength meter output, pin 13 at U1, for measuring the DC-voltage.
- 3: Adjust the coils L1-3, L2-3, L3-3, L4-3 and the two transformers TR1-3 and TR2-3 to maximum meter deflection.
- 4: Connect a distortion meter to the output of the deemphasis filter, pin 8 at U3.3-3.
- 5: Modulate the RF-carrier with a 1 kHz tone to a peak diviation of 3 kHz. Increase the RF-carrier level to -30 dBm (EMF:  $83 \text{ dB}/\mu\text{V}$ ).
- 6: Adjust the output transformer TR2-3 to minimum distortion and control that the distortion is less than 3%.

### 3.6.3. ADJUSTMENT OF RECEIVER (MODULE 3) cont.:

#### ADJUSTMENT OF AF OUTPUT LEVEL

The AF output level from the detector is adjusted to match the RX AF input level from the connected VHF transceiver.

- 1: Connect a RF-signal generator to the antenna input and adjust the carrier level to -50 dBm (EMF: 63 dB/ $\mu$ V). Modulate the carrier with 1 kHz to a peak frequency deviation of 3 kHz.
- 2: Connect a multimeter to the analog switch output, pin 14 at U6-3 for measuring the AC-voltage.
- 3: Adjust the trimpot R66-3 until the output level is 260 mV<sub>RMS</sub>  $\pm$ 5mV.

#### ADJUSTMENT OF TRIGGER LEVEL FOR CHANNEL-70 CARRIER DETECT

The channel-70 carrier detect circuit is constructed as a noise triggered squelch and the trigger level is adjusted by the trimming resistor R36-3.

- 1: Apply an unmodulated carrier with the frequency 156.525 MHz to the antenna terminal and adjust the output level of the RF-signal generator to -126 dBm (EMF: -13 dB/ $\mu$ V).
- 2: Connect a multimeter or an oscilloscope to the output of the voltage comparator, pin 14 at U4.3-3, for measuring the DC-voltage.
- 3: Turn the trimpot R36-3 counter clockwise until the output goes high.
- 4: Increase the RF-input level to -125 dBm (EMF: -12 dB/ $\mu$ V).
- 5: Now adjust R36-3 clockwise until the output goes low.
- 6: Increase the RF-input level to -122 dBm (EMF: -9 dB/ $\mu$ V) and control that the output goes high.

#### ADJUSTMENT OF TRIGGER LEVEL FOR VHF CARRIER DETECT

The VHF carrier detect circuit is identical to the corresponding carrier detect circuit for the build-in channel-70 receiver and the trigger level is adjusted by the trimming resistor R93-3.

- 1: Connect the RM2042 to the VHF transceiver by means of the 9 pole SUB-D connector.
- 2: Apply an unmodulated carrier with the frequency 156.525 MHz to the antenna terminal at the connected VHF transceiver and adjust the output level of the RF-signal generator to -126 dBm (EMF: -13 dB/ $\mu$ V).
- 3: Connect a multimeter or an oscilloscope to the output of the voltage comparator, pin 13 at U4.4-3, for measuring the DC-voltage.
- 4: Turn the trimpot R93-3 counter clockwise until the output goes high.
- 5: Increase the RF-input level to -125 dBm (EMF: -12 dB/ $\mu$ V).
- 6: Now adjust R93-3 clockwise until the output goes low.
- 7: Increase the RF-input level to -122 dBm (EMF: -9 dB/ $\mu$ V) and control that the output goes high.

### 3.6.3. ADJUSTMENT OF RECEIVER (MODULE 3) cont.:

#### ADJUSTMENT OF 10V

The 10V power supply is used by the build-in channel-70 receiver and the FSK encoder/decoder.

- 1: Connect a voltmeter to the output of the 10V power regulator, pin 1 at U10-3.
- 2: Adjust the DC voltage to  $10V \pm 10mV$ .

### 3.7. REPLACEMENT OF COMPONENTS

When replacing integrated circuits, transistors, diodes, resistors, capacitors and similar components you must use a small "pencil" soldering iron with a maximum temperature of  $300^{\circ}C$  ( $572^{\circ}F$ ). The soldering must be performed rapidly to avoid superheating and the use of a desoldering wire is recommended, as otherwise there is a risk that both the components and the printed circuit will be spoiled.

### 3.8. REPLACEMENT OF MODULES

If a fault has been located to a single module, it may often be worth-while to replace it and then repair it later on.



## **3.9. NECESSARY ADJUSTMENTS AND CHECK AFTER REPAIR**

### **3.9.1. REPAIR/REPLACEMENT OF INTERFACE MODULE (MODULE 1)**

#### **REPLACEMENT OF INTERFACE MODULE (MODULE 1).**

If the RM2042 is used in a semi automatic system, where the balanced TX AF amplifier is used, it is necessary to perform section 3.6.1, "ADJUSTMENT OF BALANCED TX AF AMPLIFIER" and then perform section 3.5, "CHECK OF SYSTEM PERFORMANCE"

However, if the RM2042 is used in a automatic system with RT2047 or RT2048 and if the interface module is replaced with a new one, which is factory adjusted, it is only necessary to perform section 3.5, "CHECK OF SYSTEM PERFORMANCE".

#### **REPAIR IN UNBALANCED/BALANCED TX AF AMPLIFIER (MODULE 1).**

Perform section 3.6.1, "ADJUSTMENT OF UNBALANCED/BALANCED TX AF AMPLIFIER".  
Perform section 3.5, "CHECK OF SYSTEM PERFORMANCE".

#### **REPAIR IN S.P. BUS INTERFACE (MODULE 1).**

Connect the RM2042 to the VHF tranceiver (RT2047 or RT2048) by means of the 9 pole SUB-D connector P2-1 and select the 'VHF CH' menu at the RM2042.  
Now try to key-in a channel number with two digits (e.g. channel number 12) and control that the channel number also change in the display at the VHF tranceiver.

#### **REPAIR IN PRINTER INTERFACE (MODULE 1).**

Press the 'FUNC' button and select the 'Print' menu, by pressing 'NEXT'. Use the 'up-arrow' or 'down-arrow' to select 'Options/setup'. Start the print procedure by pressing 'NEXT' and control that the options/setup parameters are printed correctly.

#### **REPAIR IN C2149/PC INTERFACE (MODULE 1).**

Connect a GPS receiver to the remote control unit C2149 and connect this unit to the VHF DSC RM2042. Disconnect any GPS input to the RM2042 it self.  
Press the 'FUNC' button and select the 'Position' menu. Control that the ships position is continously updated and equals the position determined by the GPS receiver.  
NOTE! The position update rate may be very slow.

#### **REPAIR IN NMEA INTERFACE (MODULE 1).**

Connect a GPS receiver to the VHF DSC unit and control that the ships position is updated as described above.

### 3.9.2. REPAIR/REPLACEMENT OF MICROPROCESSOR MODULE (MODULE 2)

#### REPLACEMENT OF MICROPROCESSOR MODULE (MODULE 2).

If the microprocessor module is replaced with a new one, which is factory adjusted, it is only necessary to perform section 3.5, "CHECK OF SYSTEM PERFORMANCE".

#### REPLACEMENT OF SOFTWARE (MODULE 2).

Perform section 3.5, "CHECK OF SYSTEM PERFORMANCE".

#### REPAIR IN 4.9152 MHz OSCILLATOR (MODULE 2).

Perform section 3.6.2, "ADJUSTMENT OF 4.9152 MHz OSCILLATOR".

Perform section 3.5, "CHECK OF SYSTEM PERFORMANCE".

#### REPAIR IN 32.768 kHz OSCILLATOR (MODULE 2).

Perform section 3.6.2, "ADJUSTMENT OF 32.768 kHz OSCILLATOR".

Check that the real time clock is performing correctly, by inspection of the display.

### 3.9.3. REPAIR/REPLACEMENT OF RECEIVER MODULE (MODULE 3)

#### REPLACEMENT OF RECEIVER MODULE (MODULE 3).

If the receiver module is replaced with a new one, which is factory adjusted, it is only necessary to perform section 3.5, "CHECK OF SYSTEM PERFORMANCE".

#### REPAIR IN RECEIVER FRONT-END, FIRST MIXER AND 1st. IF. (MODULE 3).

Perform section 3.6.3, "ADJUSTMENT OF FRONT-END FILTERS AND MIXER TRANSFORMERS".

Perform section 3.5, "CHECK OF RECEIVER SENSITIVITY".

#### REPAIR IN LO1. (MODULE 3).

Perform section 3.6.3, "ADJUSTMENT OF FIRST LOCAL OSCILLATOR".

Perform section 3.5, "CHECK OF RECEIVER SENSITIVITY".

#### REPAIR IN LO2 AND 2nd IF. (MODULE 3).

Perform section 3.6.3, "ADJUSTMENT OF SECOND LOCAL OSCILLATOR".

Perform section 3.6.3, "ADJUSTMENT OF AF OUTPUT LEVEL".

Perform section 3.5, "CHECK OF RECEIVER SENSITIVITY".

#### REPAIR IN AF FILTERS (MODULE 3).

Perform section 3.5, "CHECK OF RX AF FILTER RESPONSE".

Perform section 3.5, "CHECK OF DSC CALL SENSITIVITY".

**3.9.3. REPAIR/REPLACEMENT OF RECEIVER MODULE (MODULE 3) cont.:**

**REPAIR IN FSK ENCODER/DECODER (MODULE 3).**

Perform section 3.5, "CHECK OF TX AF LEVEL".

Perform section 3.5, "CHECK OF TX AF DISTORTION".

Perform section 3.5, "CHECK OF DSC CALL SENSITIVITY".

**REPAIR IN CHANNEL-70 CARRIER DETECT (MODULE 3).**

Perform section 3.6.3, "ADJUSTMENT OF TRIGGER LEVEL FOR CHANNEL-70 CARRIER DETECT"

**REPAIR IN VHF CARRIER DETECT (MODULE 3).**

Perform section 3.6.3, "ADJUSTMENT OF TRIGGER LEVEL FOR VHF CARRIER DETECT"

### 3.10. PIN CONFIGURATIONS

#### DIODE:

BAT54S (SOT-23 CASE)

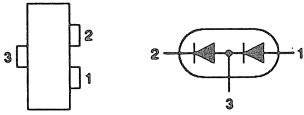

#### TRANSISTOR:

BC848B, BC858B, BFR92A (SOT-23 CASE)

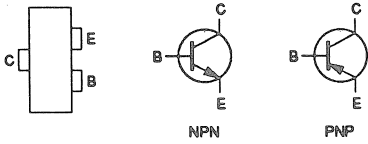

BF996SB (SOT-143 CASE)

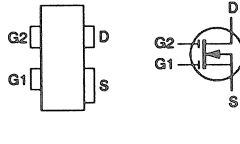

BCP52-16, BCP55-16 (SOT-223 CASE)

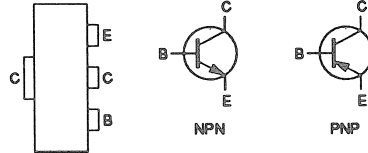

TIS88 (SOT-23 CASE)

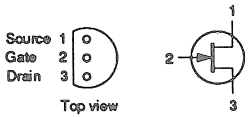

#### VOLTAGE REGULATOR and CONVERTER:

7805 (TO-220 CASE)

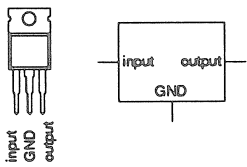

78M05 (DPAK PACKAGE)

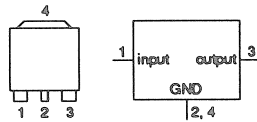

78L05 (SO-8 PACKAGE)

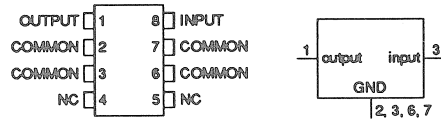

LP2951 (SO-8 PACKAGE)

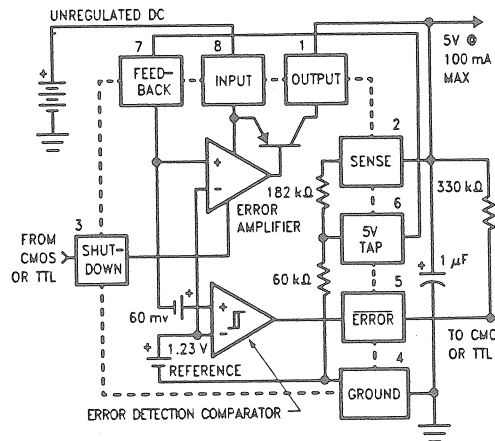
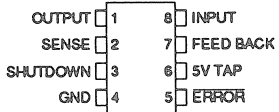

LTC1044 (SO-8 PACKAGE)

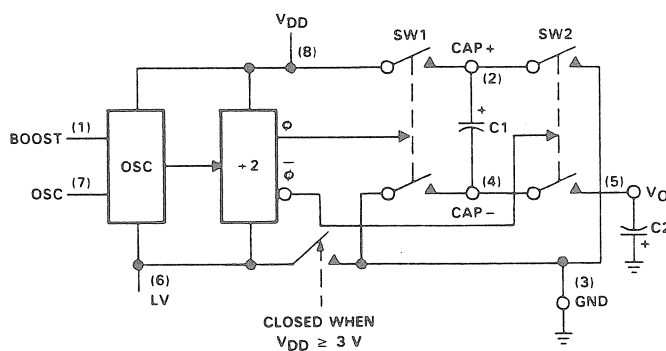
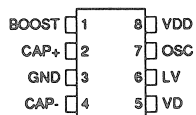

### 3.10. PIN CONFIGURATIONS cont.:

#### INTEGRATED CIRCUIT, ANALOG:

LM324 (SO-8 PACKAGE)

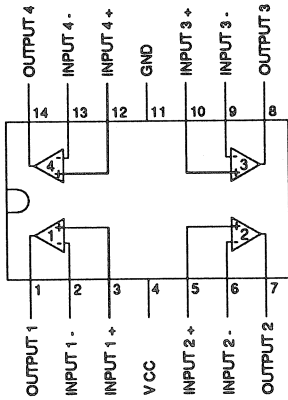

LM339 (SO-8 PACKAGE)

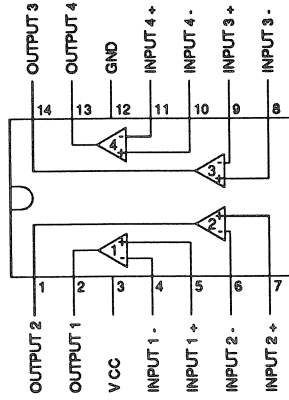

MC3372 (SO-16 CASE)

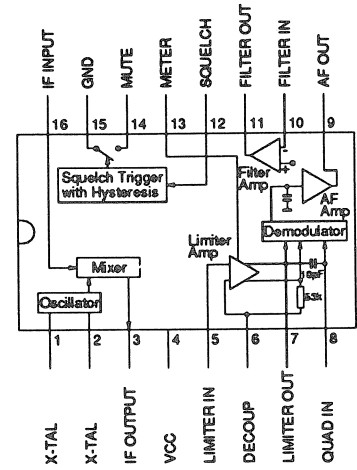

TDA7052 (DIL-8 PACKAGE)

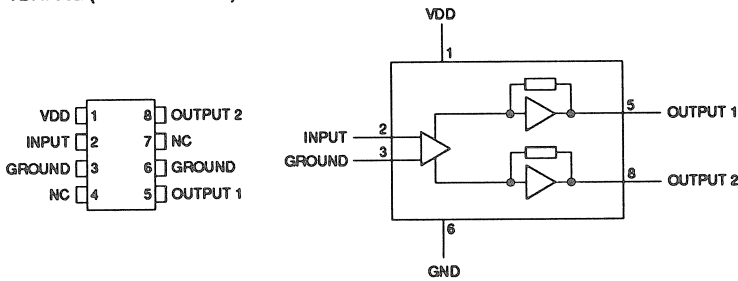

MSM6927 (24-LEAD FLAT-PACK)

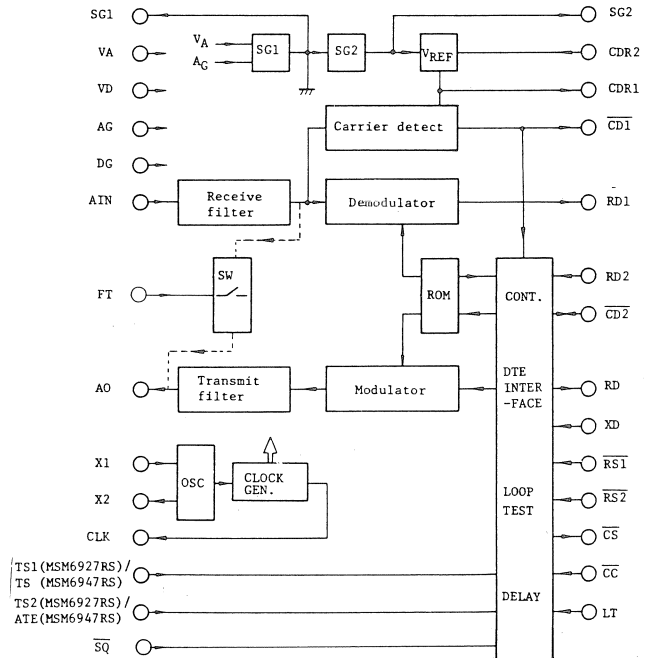
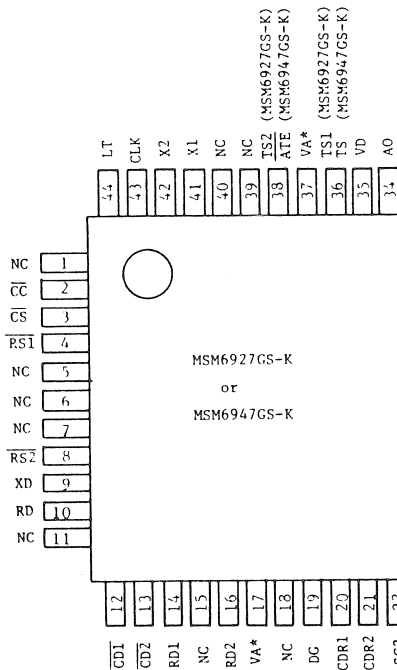

3.10. PIN CONFIGURATIONS cont.:

INTEGRATED CIRCUIT, DIGITAL:

68HC000 (68-LEAD PLCC PACKAGE)

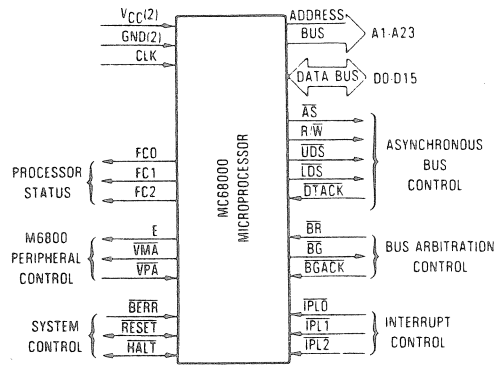
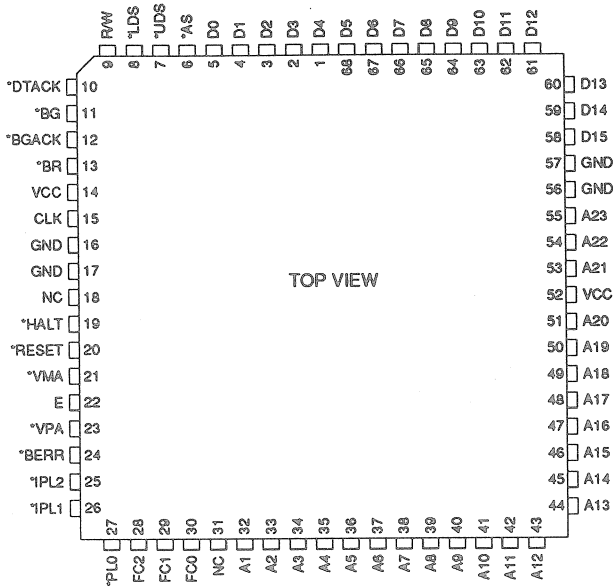

MSM5165/OKI & HM6264/HITACHI (28-LEAD FLAT-PACK)

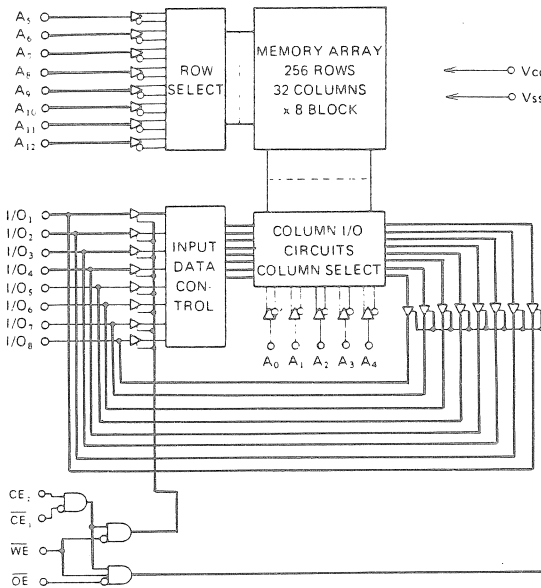
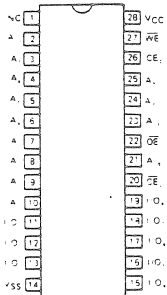

27PC512 (28-LEAD PLCC PACKAGE)

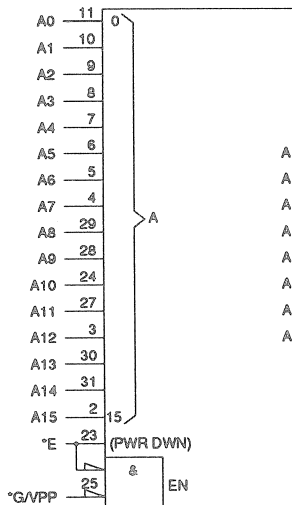
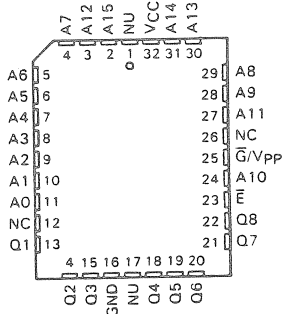

3.10. PIN CONFIGURATIONS cont.:

28C64A (32-LEAD PLCC PACKAGE)

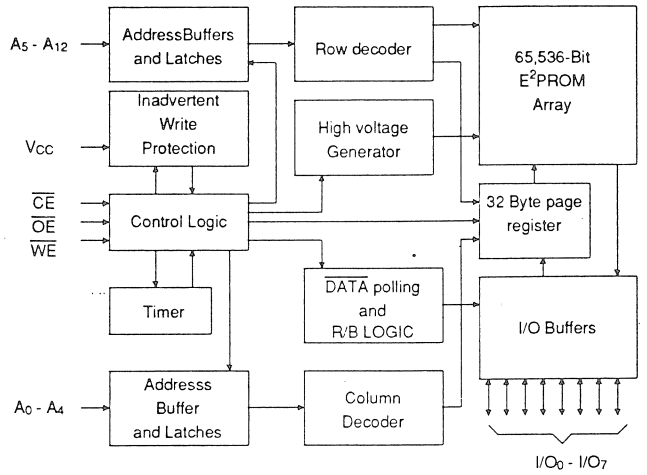
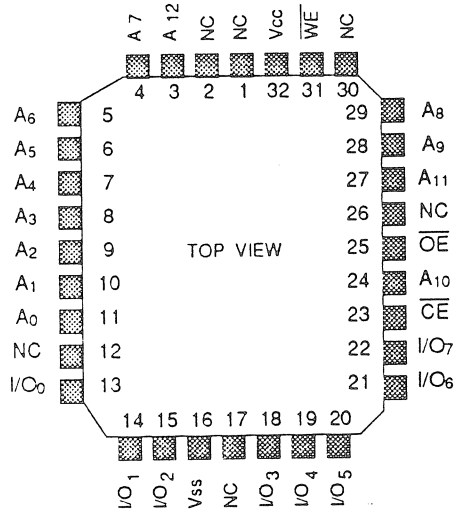

71051/NEC & 82C51/OTHERS (28-LEAD PLCC PACKAGE)

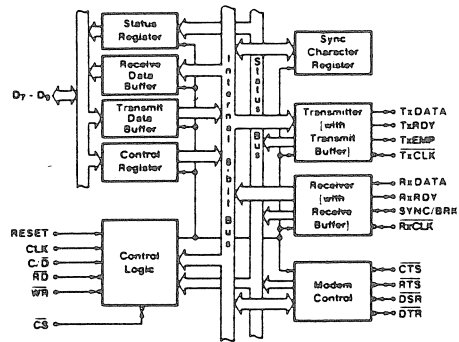
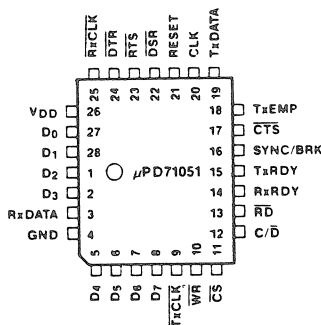

83-000782A

71054/NEC & 82C54/OTHERS (28-LEAD PLCC PACKAGE)

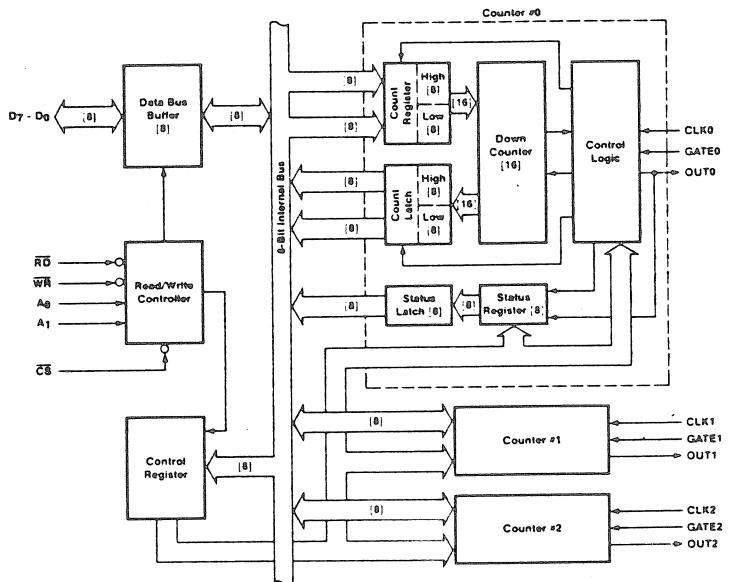
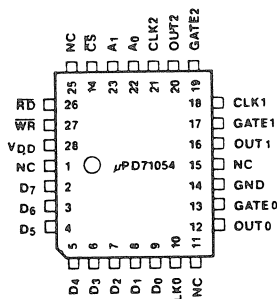

### 3.10. PIN CONFIGURATIONS cont.:

#### 71055/NEC & 82C55/OTHERS (44-LEAD PLCC PACKAGE)

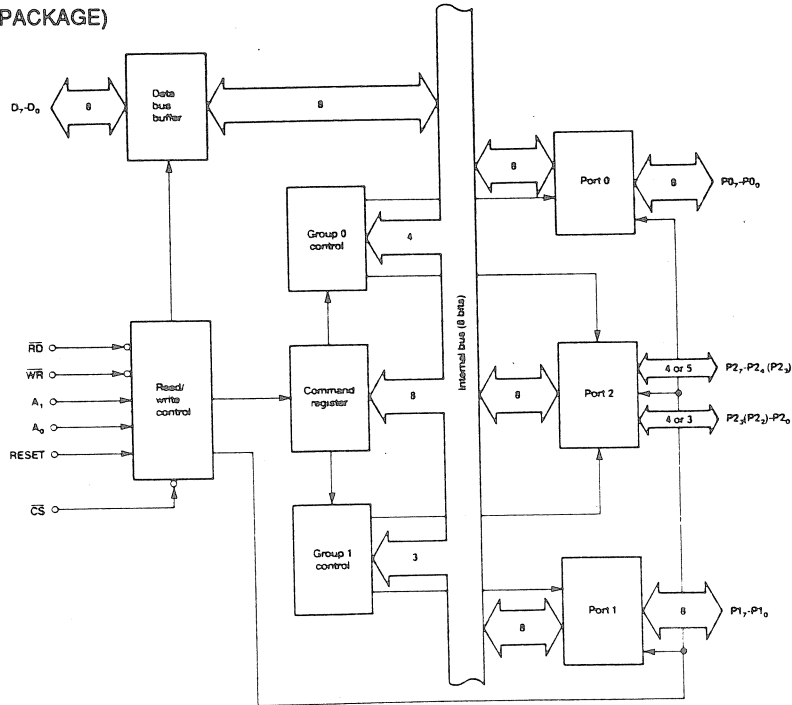
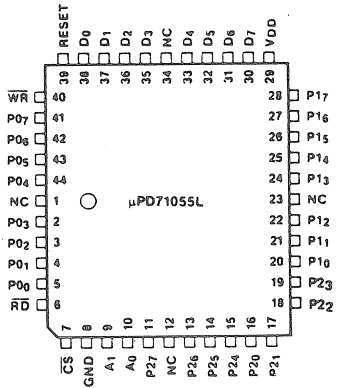

#### 8573A (28-LEAD PLCC PACKAGE)

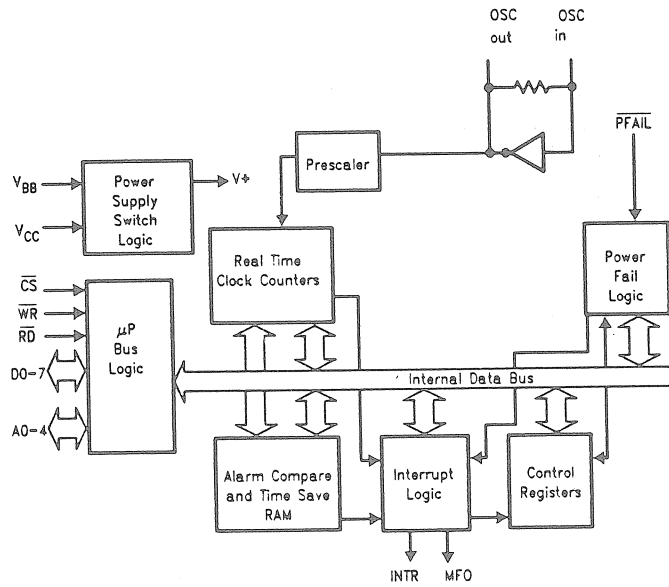
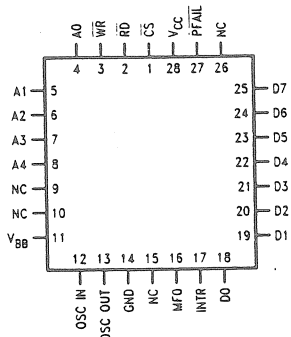

#### AD232 (SO-16L PACKAGE)

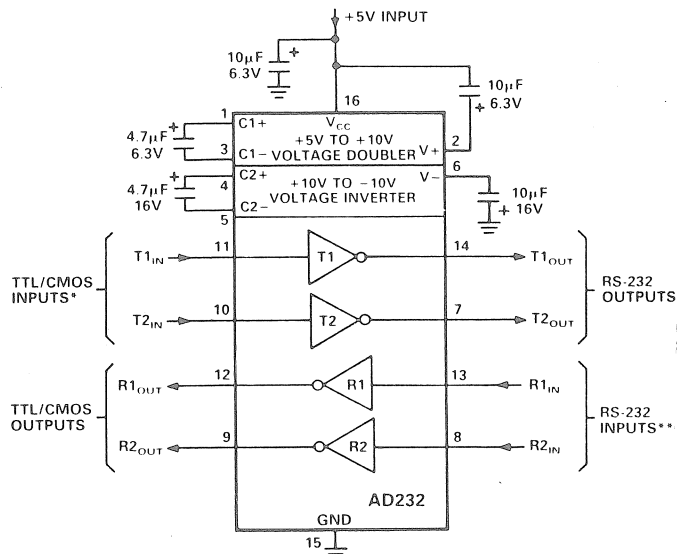
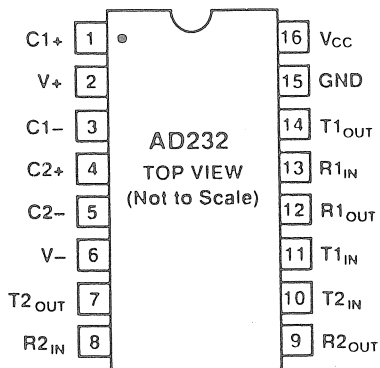



3.10. PIN CONFIGURATIONS cont.:

MOC207 (SO-8 PACKAGE)

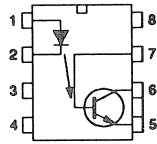

74HC00 (SO-14 PACKAGE)

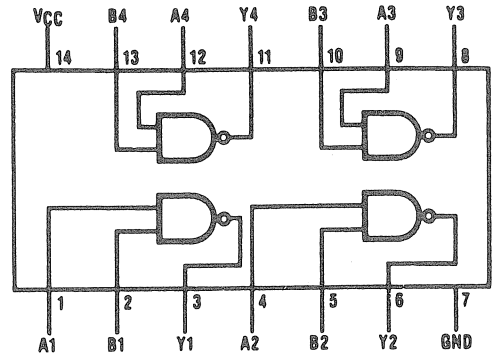

74HC02 (SO-14 PACKAGE)

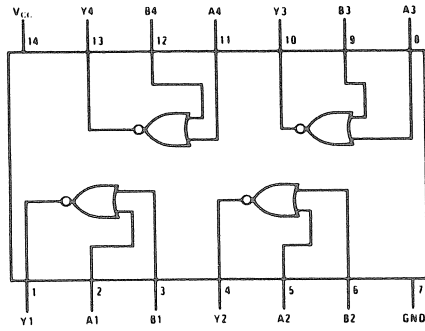

74HC04 (SO-14 PACKAGE)

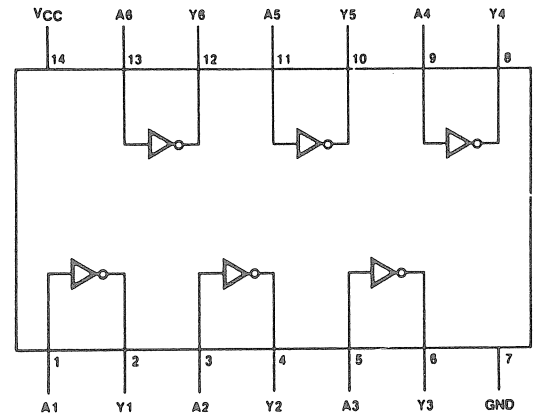

74HC05 (SO-14 PACKAGE)

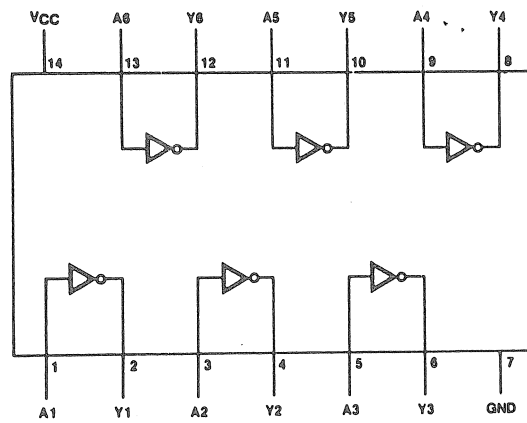

74HC08 (SO-14 PACKAGE)

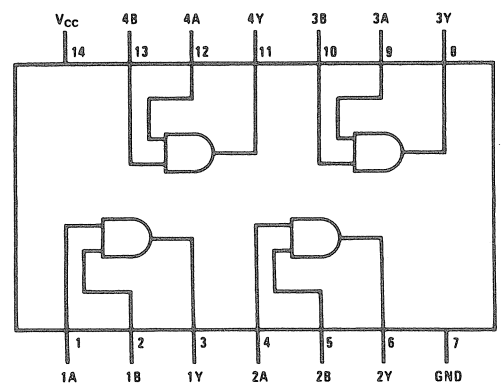

74HC14 (SO-14 PACKAGE)

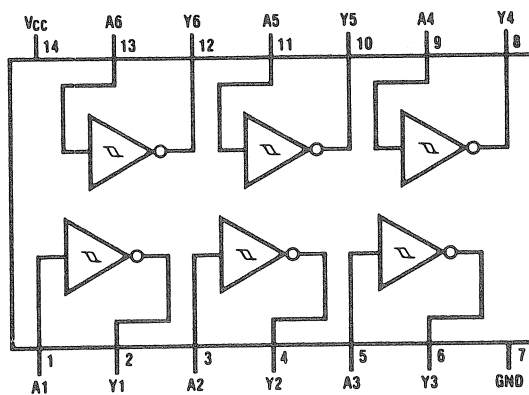

74HC21 (SO-14 PACKAGE)

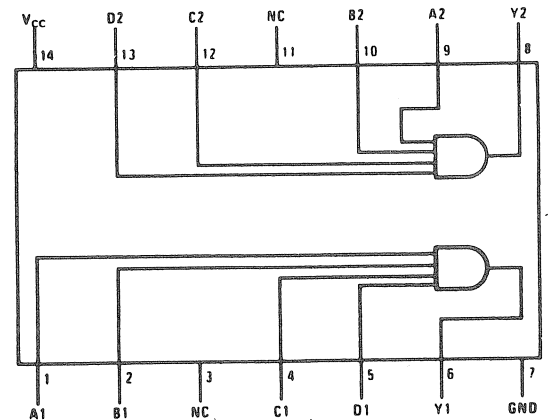

3.10. PIN CONFIGURATIONS cont.:

74HC32 (SO-14 PACKAGE)

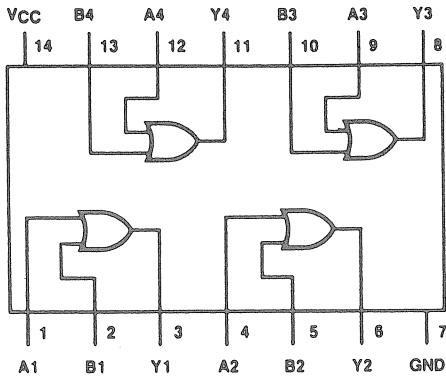

74HC74 (SO-14 PACKAGE)

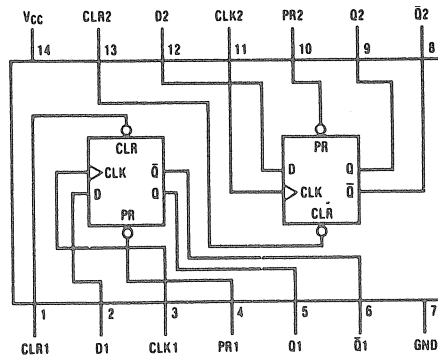

74HC132 (SO-14 PACKAGE)

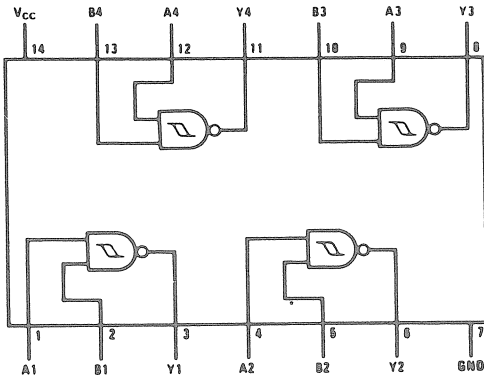

74HC138 (SO-16 PACKAGE)

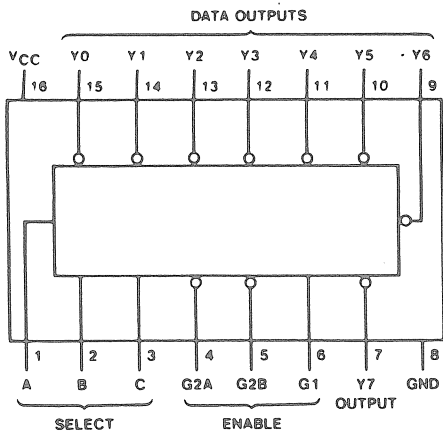

Inputs		Outputs										
Enable		Select										
G1	G2*	C	B	A	Y0	Y1	Y2	Y3	Y4	Y5	Y6	Y7
X	H	X	X	X	H	H	H	H	H	H	H	H
L	X	X	X	X	H	H	H	H	H	H	H	H
H	L	L	L	L	L	H	H	H	H	H	H	H
H	L	L	L	H	H	L	H	H	H	H	H	H
H	L	L	H	H	H	H	H	L	H	H	H	H
H	L	H	L	L	H	H	H	H	L	H	H	H
H	L	H	L	H	H	H	H	H	H	L	H	H
H	L	H	H	L	H	H	H	H	H	H	L	H
H	L	H	H	H	H	H	H	H	H	H	H	L

\* G2 = G2A + G2B  
H = high level, L = low level, X = don't care

74HC148 (SO-16 PACKAGE)

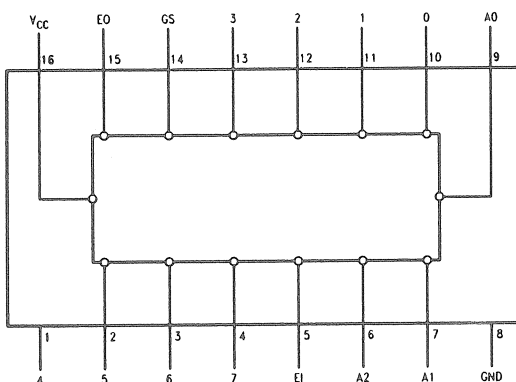

Inputs		Outputs											
EI	0	1	2	3	4	5	6	7	A2	A1	A0	GS	E0
H	X	X	X	X	X	X	X	X	H	H	H	H	H
L	H	H	H	H	H	H	H	H	H	H	H	H	L
L	X	X	X	X	X	X	L	L	L	L	L	L	H
L	X	X	X	X	X	L	H	L	L	L	L	L	H
L	X	X	X	X	L	H	H	L	H	L	L	L	H
L	X	X	L	H	H	H	H	H	L	L	L	L	H
L	X	L	H	H	H	H	H	H	L	L	L	L	H
L	X	L	H	H	H	H	H	H	H	L	L	L	H

H = High, L = Low, X = irrelevant

### 3.10. PIN CONFIGURATIONS cont.:

74HC154 (SO-24L PACKAGE)

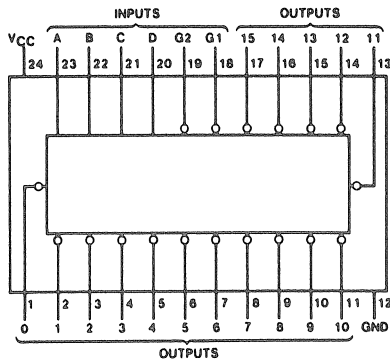

Inputs						Low Output*
$\overline{G1}$	$\overline{G2}$	D	C	B	A	
L	L	L	L	L	L	0
L	L	L	L	L	H	1
L	L	L	L	H	L	2
L	L	L	L	H	H	3
L	L	L	H	L	L	4
L	L	L	H	L	H	5
L	L	L	H	H	L	6
L	L	L	H	H	H	7
L	L	H	L	L	L	8
L	L	H	L	L	H	9
L	L	H	L	H	L	10
L	L	H	L	H	H	11
L	L	H	H	L	L	12
L	L	H	H	L	H	13
L	L	H	H	H	L	14
L	L	H	H	H	H	15
L	H	X	X	X	X	—
L	L	X	X	X	X	—
H	H	X	X	X	X	—

\*All others high

74HC174 (SO-16 PACKAGE)

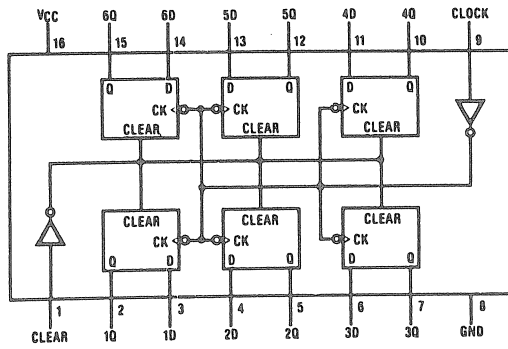

Inputs			Outputs
Clear	Clock	D	Q
L	X	X	L
H	↑	H	H
H	↑	L	L
H	L	X	Q <sub>0</sub>

H = High level (steady state)  
 L = Low level (steady state)  
 X = Don't Care  
 ↑ = Transition from low to high level  
 Q<sub>0</sub> = The level of Q before the indicated steady state input conditions were established.

74HC393 (SO-14 PACKAGE)

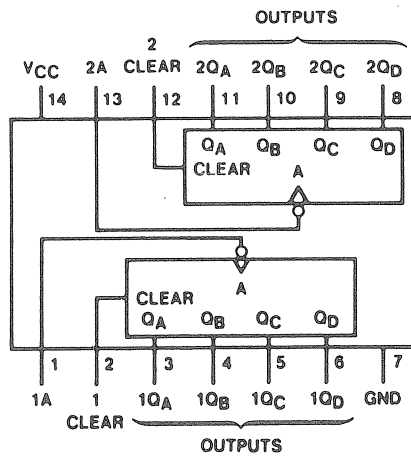

74HC4053 (SO-16 PACKAGE)

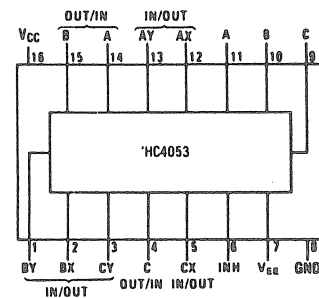

74HC4040 (SO-16 PACKAGE)

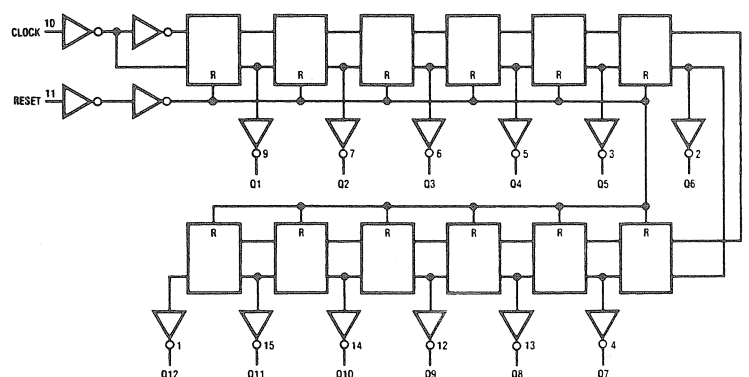
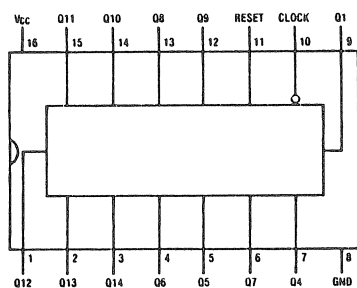

## CONTENTS

- 4. MECHANICAL DESCRIPTION
- 4.1. MECHANICAL DISASSEMBLING AND MODULE LOCATION



4. MECHANICAL DESCRIPTION

4.1 MECHANICAL DISASSEMBLING AND UNITS LOCATION

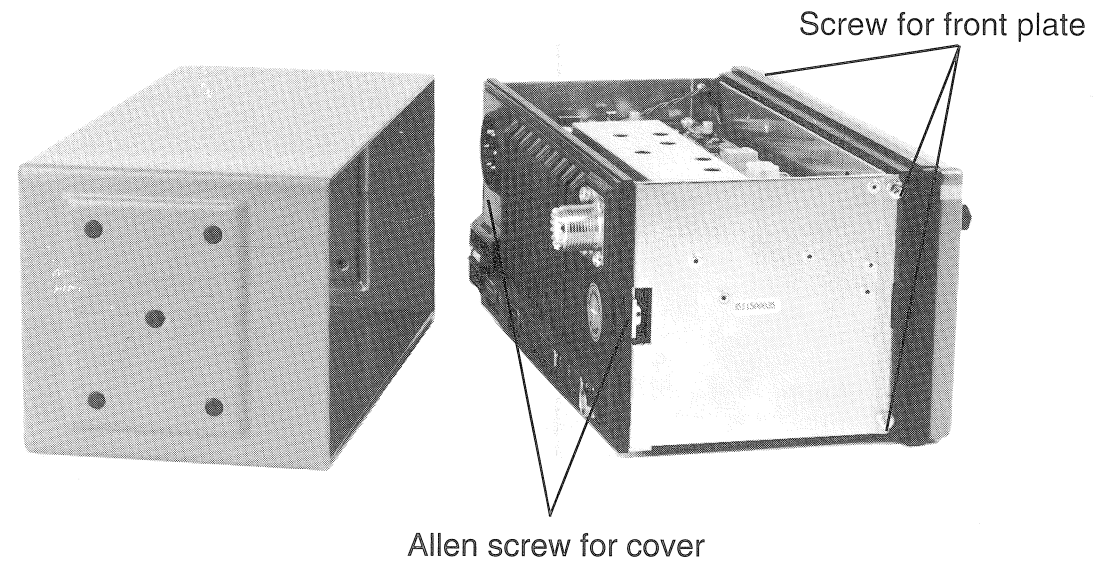

Top view

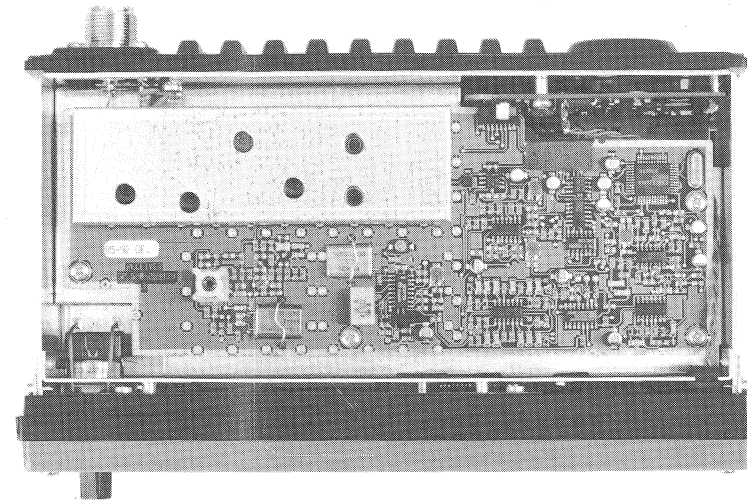

Bottom view

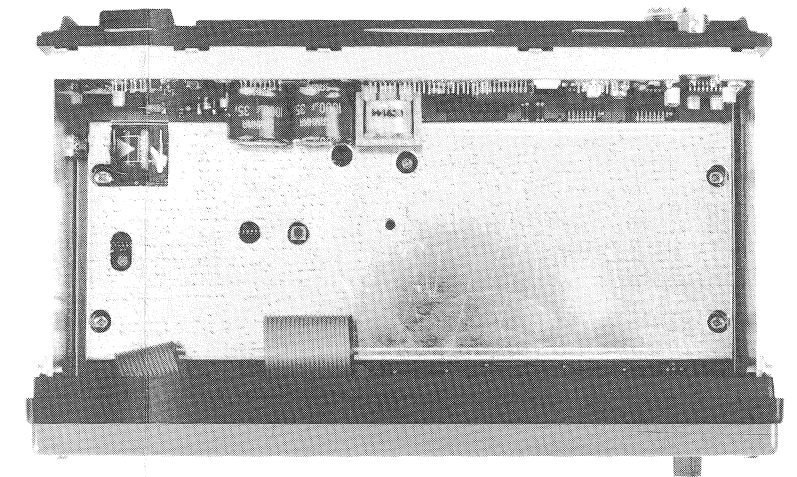

Front view without frontplate  
Screw for Display section

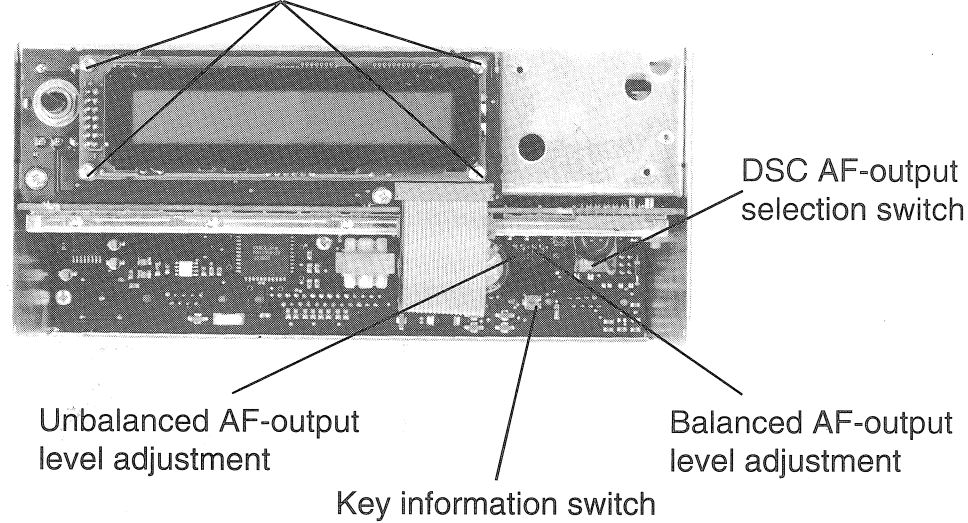

Screw for Microprocessor module

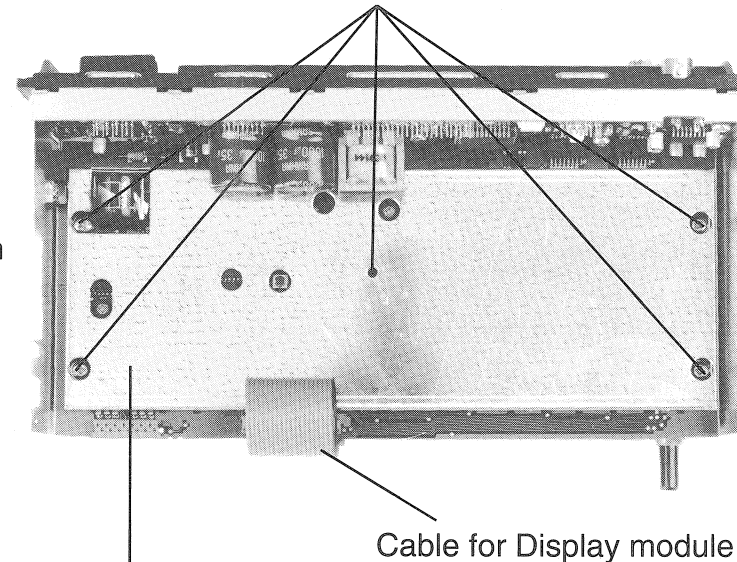

Clock backup battery

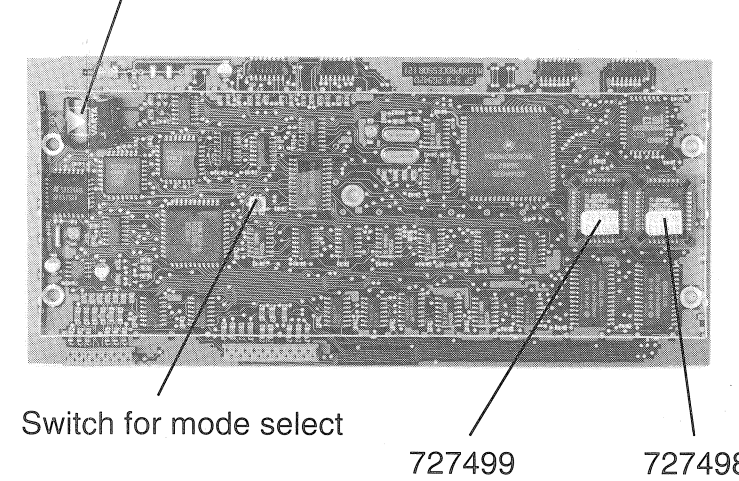

RM2042  
501225 501226 501227  
501229 501232 501236



## CONTENTS

- 5. CIRCUIT DESCRIPTION AND SCHEMATIC DIAGRAMS
  - 5.1. INTERFACE (MODULE 1)
  - 5.2. MICROPROCESSOR (MODULE 2)
  - 5.3. RECEIVER (MODULE 3)
  - 5.4. DISPLAY UNIT (MODULE 4)
  - 5.5. KEYBOARD (MODULE 5)
  - 5.6. INTERCONNECTION CABLE DIAGRAM





## 5. CIRCUIT DESCRIPTION AND SCHEMATIC DIAGRAMS

### 5.1. INTERFACE (MODULE 1)

All connections to external equipment and the corresponding interface circuits are located at the interface module. The interface circuits are in this discription divided into the following blocks, which again are divided into an analog and a digital groupe:

#### Analog interface

- Loudspeaker amplifier
- Balanced TX AF amplifier
- Unbalanced TX AF amplifier
- 12V/24V wiring circuit
- 5V power supply
- Power failure reset circuit

#### Digital interface

- S.P. bus interface
- Printer interface
- C2149/PC interface
- NMEA interface (Navigational equipment interface according to the National Marine Electronics Association)

#### LOUDSPEAKER AMPLIFIER

The loudspeaker amplifier is build-up around the integrated power amplifier TDA7052 (U4), which has a voltage gain of about 40dB and is able to deliver about 0.5 Watt into an 8 ohm loudspeaker.

In a normal operation situation, where no call signal has been detected, the received signal from the external connected VHF or the build-in channel-70 receiver will be leaded to the internal loudspeaker. The received signal comming from the receiver module is buffered by an operational amplifier (U3.4) and is then led to the volume control at the front panel, where it is attenuated. The attenuated signal is buffered at the interface module by the transistor Q8 and then finally led to the power amplifier and loudspeaker. If a call signal (distress or ordinary) is received, the microprocessor will generate an indication signal (gated 600Hz tone) that will be leaded to the loudspeaker instead of the received signal. The received signal is removed from the loudspeaker by means of the transistor Q3, which at the same time is grounding the signal and removing the bias for the buffer transistor Q8. The controle signal to transistor Q3 is generated by the printer interface unit U10 and is filtered by R13, R14 and C52 to avoid a suddenly change in the bias of transistor Q8, which else would result in an irritating "DC-blop" in the loudspeaker.

#### BALANCED TX AF AMPLIFIER

The VHF DSC RM2042 has two seperate transmitter outputs - an unbalanced with a low generator impedance and a balanced with a 600 ohm generator impedance. To establish a balanced connection between RM2042 and the connected VHF radiotelephone, it will be necessary to use two wires, while an unbalanced connection only requires one. Because the number of wires in the connection cable is limit to nine and all are in use, it is necessary to change the function of the serial data bus and use this as the second wire in the balanced connection. As a consequence, the balanced connection can not be used in instalations where RM2042 is connected to the duplex VHF radiotelephone RT2047 or the simplex VHF radiotelephone RT2048, because the serial data communication is essential in these cases. The switching between balanced and unbalanced mode is done manually by turning the switch S1 with a screwdriver or equal.

## 5.1. INTERFACE (MODULE 1) cont.:

The input signal to the balanced TX AF amplifier is a FSK-signal (Frequency-Shift Keying signal), which is generated by the MODEM-IC located at the Receiver Module. This FSK-signal is led to the operational amplifier (U3.2) and the transistor Q4 at the Interface Module. The feedback signal to the OP AMP is taken from the emitter of Q4, which minimize the harmonic distortion. The balance is obtained by means of the transformer TR1, which is placed between the battery voltage and the collector of Q4. The output level is adjustable from -10dBm to +10dBm (600 ohm) and is controlled by the trimming potentiometer R17.

### UNBALANCED TX AF AMPLIFIER

As mentioned above the unbalanced output has to be used, if RM2042 is connected to RT2047 or RT2048. The input signal to the unbalanced TX AF amplifier is attenuated and buffered by the operational amplifier U3.3. The output level is adjustable from -30dBm to -10dBm and is controlled by the trimming potentiometer R22.

### 12V/24V WIRING CIRCUIT

The RM2042 can be supplied from two different sources, which are:

- 12V battery
- SAILOR power supply, N420 or N418 (24V to 12V)

To select the wanted power source, the interface module is mounted with a strap field, which is accessible from the rear panel. How to code this strap field is shown in chapter 2, which deal with the installation of RM2042.

### 5V POWER SUPPLY

The interface module include two separate 5V serial regulators. The one, U5, is only used to supply the loudspeaker amplifier and this voltage is designated +5VA in the diagram. The other one, U1, is used to supply all digital circuits at the interface, microprocessor and display modules. This regulator is constructed with an energy reservoir at its input terminal. The energy reservoir is realized by a 1000F capacitor (C3). This capacitor is able to hold the regulator output constantly at 5V for a periode of about 20msecs, even if the supply voltage is completely removed. This time periode is sufficient for the microprocessor to succeed the saving of all importen data. The hold function of the 5V supply voltage is included to handle situations, where RM2042 is turned off or the power supply voltage is removed because of a failure. The diode D1 is used to avoid immediate discharging of C3, if the input power supply voltage is grounded in a failure situation.

### POWER FAILURE RESET CIRCUIT

The power failure reset circuit is included to handle those cases, where the input power supply voltage shortly drops out. Such a power failure will immediately be detected by the microprocessor by means of an error signal, which is generated by the 10V voltage regulator at the receiver module. The microprocessor will then save all data and write an error message to the display.

If the power supply is completely lost, the RM2042 will simply be turned off and when the power supply is re-established, the RM2042 will be restarted by a power on reset pulse, generated at the microprocessor module.

But if the input power supply only drops out shortly, the 5V may not be lost completely, because the capacitor C3 will hold this voltage for about 20msecs. If the 5V supply for a short instant drops to about 4.5V, the microprocessor will probably lose control and may then by an accident overwrite someimporten data. To avoid this situation it is necessary to reset the microprocessor, which is done by the power failure reset circuit at the interface module. This circuit is build-up around the voltage comparator U2.3 and use a divided part of the 10V supply voltage as reference. The capacitor C63 is used to hold the reference voltage and the diode D7 avoid discharging backward to the 10V supply, when this drops out. Under normale operation condition, the voltage at the noninverting terminal will be higher than the reference at the inverting terminal and the output voltage will then be high. If the 5V supply voltage shortly drops below 4.5V, the voltage at the noninverting terminal will be lower than the reference voltage and the output voltage

## 5.1. INTERFACE (MODULE 1) cont.:

will then go low. This will hold the microprocessor in reset in a periode, determined by the capacitor C27 and the two resistors R27 and R75.

### S.P. BUS INTERFACE

The serial S.P. bus interface is implemented in order to be able to control a connected S.P. VHF transceiver. The connected VHF has to have a similar serial interface in order to be fully controllable for automatic/semi-automatic operation. If the connected VHF does not have a S.P. bus interface RM2042 can only function as a DSC encoder.

Data is sent and received by the UART U9. The transmission rate is 4800 baud, even parity, 8 data bits, and 1 stopbit or in RS232 terms 4800, E, 8, 1. When the UART are ready to transmit another databyte, it uses the TXRDY pin to interrupt the microprocessor.

The received serial data is stripped for start, parity and stopbits and converted to parallel data. When a parallel databyte is ready, the UART uses RXRDY to interrupt the microprocessor, which fetches the byte for further processing.

The UART is a full duplex device, but the interface is constructed with a single line by means of Q6 and U2.1, using half duplex communication. In order to avoid conflict on the line, a master/slave relationship is established. RM2042 is the master and has control over the line. If the VHF wants to use the line it interrupts RM2042 via pin 7 in P2.

The signal levels are 0 and 5V DC.

### PRINTER INTERFACE

The printer interface is a Centronics compatible parallel interface implemented by the port IC U10.

The microprocessor writes parallel data to port A. When data is accepted by the port IC, pin PC7 goes low, and the printer strobe generator circuit on the microprocessor module, generates a 2 s delayed, and 4 s wide logical low strobe. The printer answers by setting the busy flag high (input to PC0). When the printer has processed the data, the busy flag is removed (now logical low), and the printer generates a logical low acknowledge pulse which is input to pin PC6. PC7 changes to logical high, and the port IC is ready to write another byte to the printer. If PC6 is kept low, data written to port A is lost, because output on PC7 is inhibited and no strobe is generated.

### C2149/PC INTERFACE

The C2149/PC interface is a standard RS232C interface implemented with the UART U8 and the RS232 line driver/line receiver U11. U11 generates the RS232 signal levels of +/-9V from the single 5V supply. The UART handles the transmission and reception of serial data. The transmission rate is 4800, E, 8, 1. During transmission, the UART uses TXRDY to interrupt the microprocessor when it is ready to transmit another byte. During reception, the UART uses RXRDY to interrupt the microprocessor and tell that a byte has been received.

If a C2149 remote box is connected, it can receive its supply voltage via pin 6 in J3.

### NMEA 0183 INTERFACE

NMEA0183 is the international standard for interfacing marine electronics navigational devices.

NMEA0183 provides for asynchronus transmission, with a single talker and multiple listeners per line. The standard uses an 8 bit ASCII, parity disabled, block oriented protocol with a transmission rate of 4800 baud.

The incoming signal is electrically isolated from RM2042, by the optocoupler OC1. Because of the signal deformation in the optocoupler, the signal is sent trough the Schmitt-trigger build round U2.4. The serial data is received by the UART U7. The UART uses RXRDY to interrupt the microprocessor whenever a byte is received.





### 5.1. COMPONENT LOCATION INTERFACE (MODULE 1)

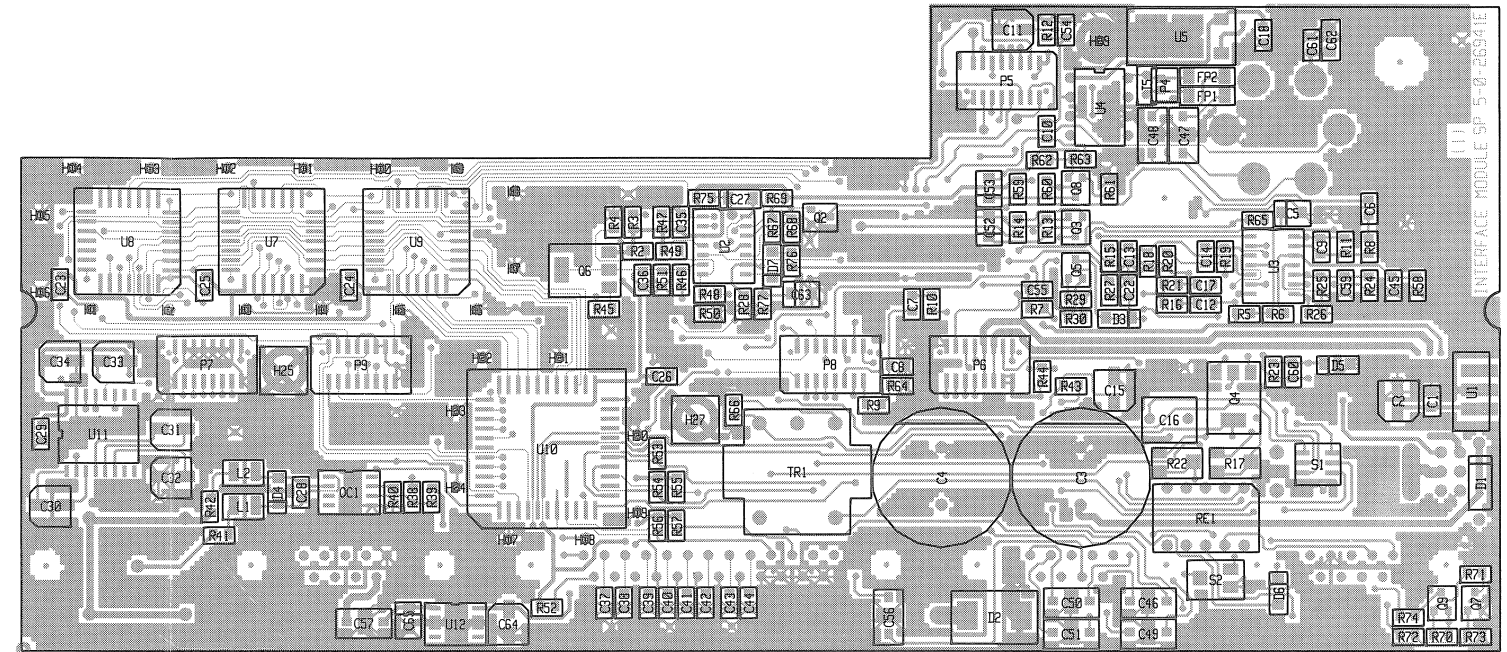

Seen from component side with upper side tracks.

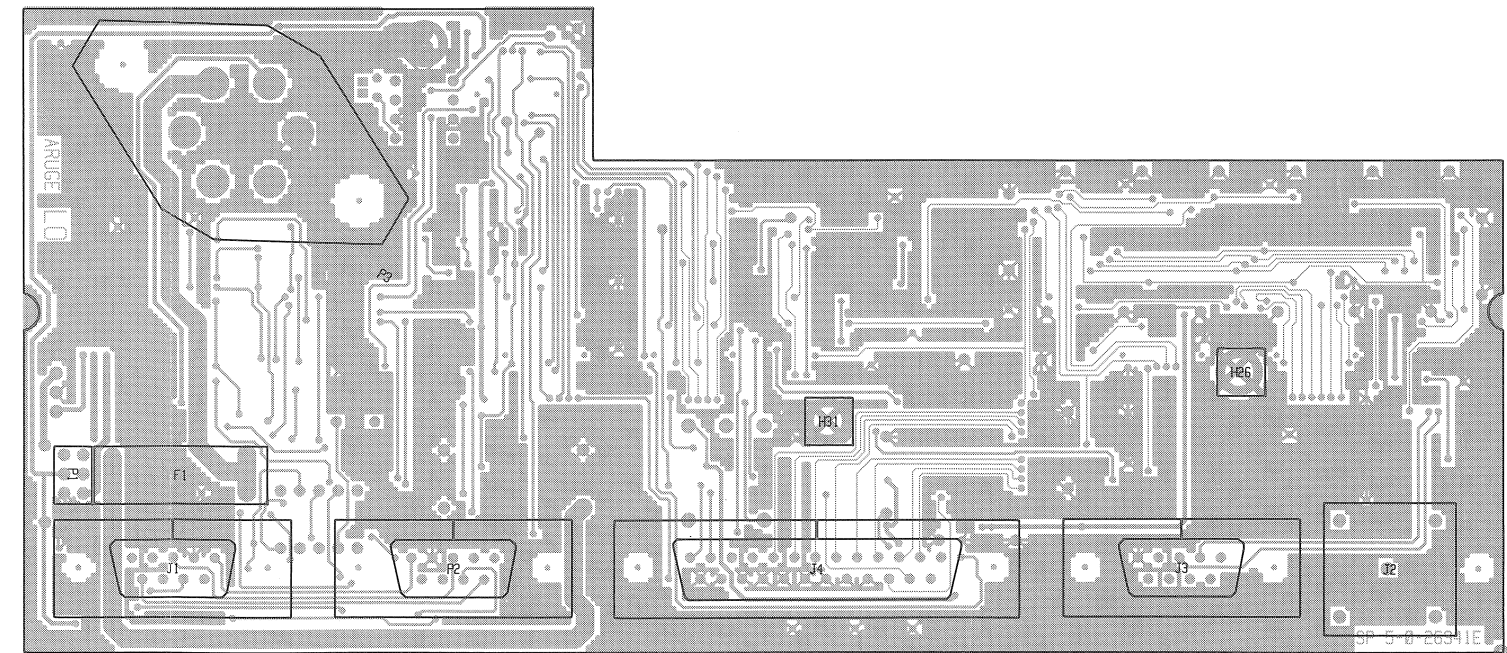

Seen from soldering side with lower side tracks.





### 5.1. COMPONENT LOCATION INTERFACE (MODULE 1)

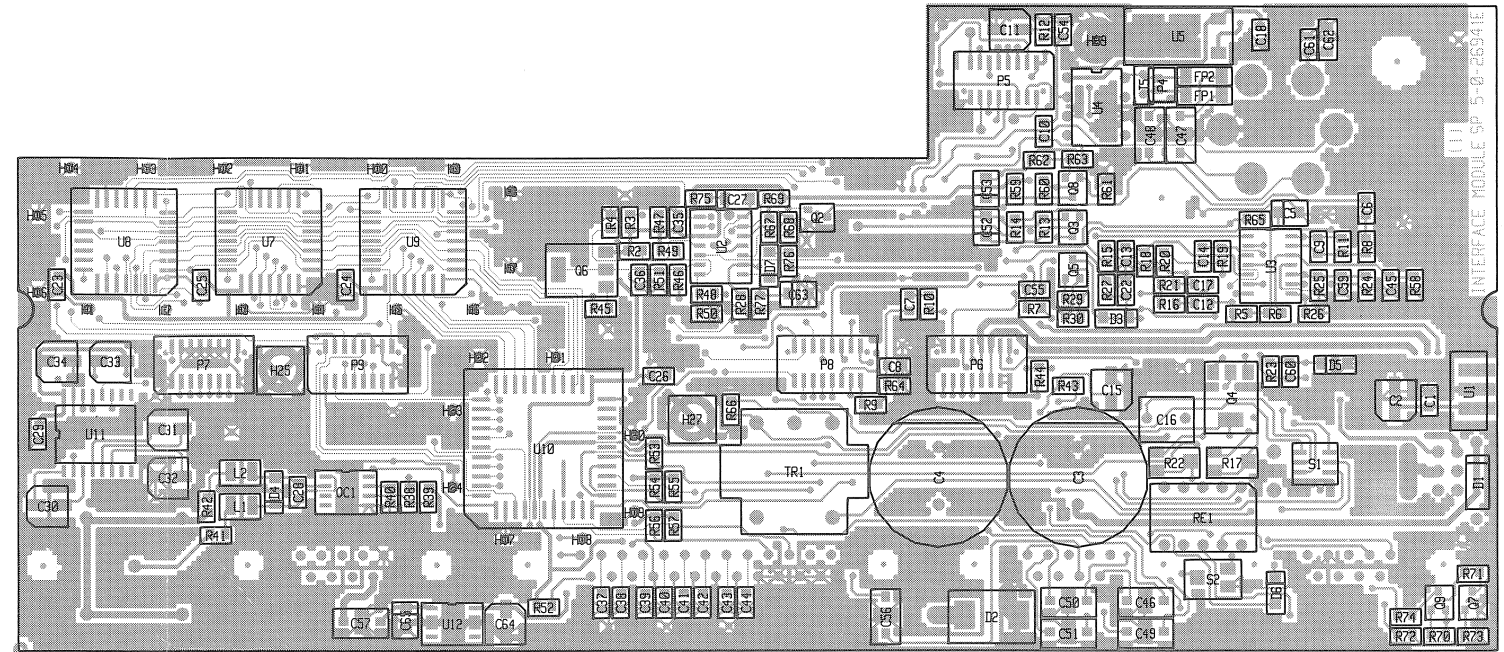

Seen from component side with upper side tracks.

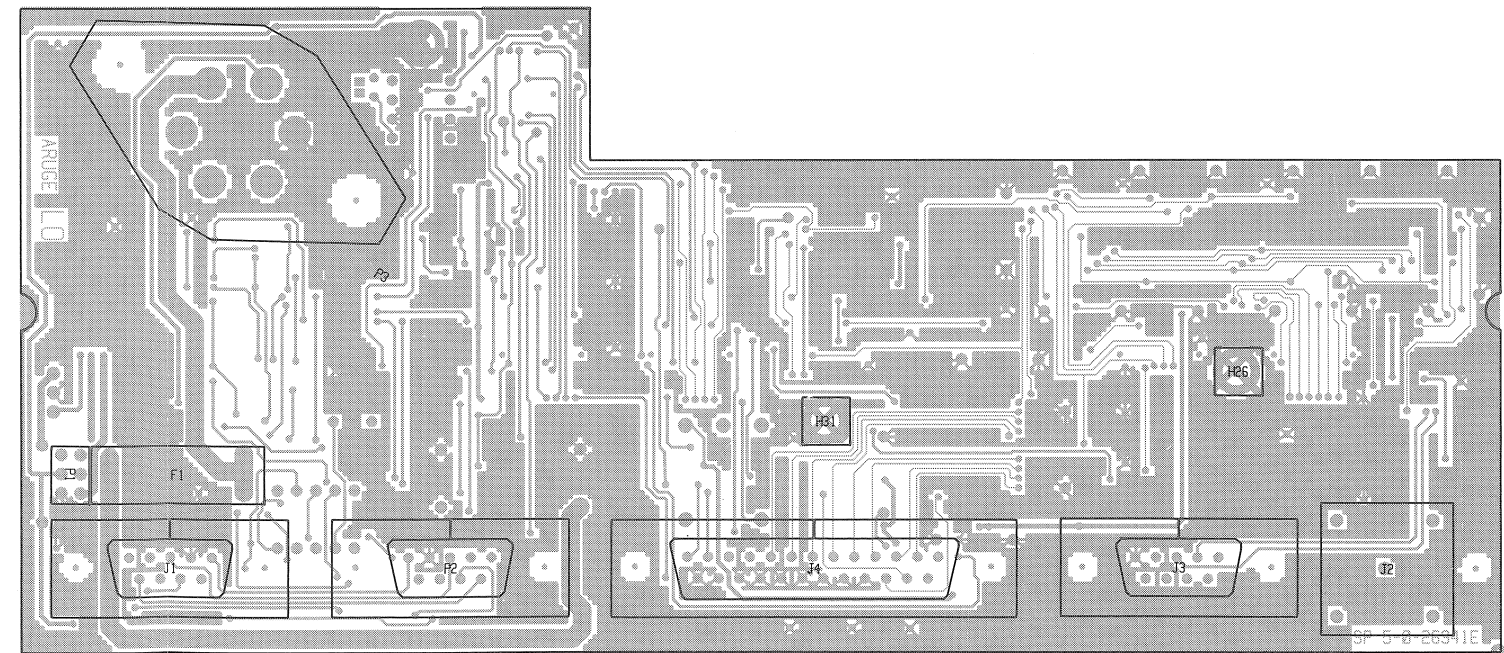

Seen from soldering side with lower side tracks.

# 5.1. INTERFACE (MODULE 1)

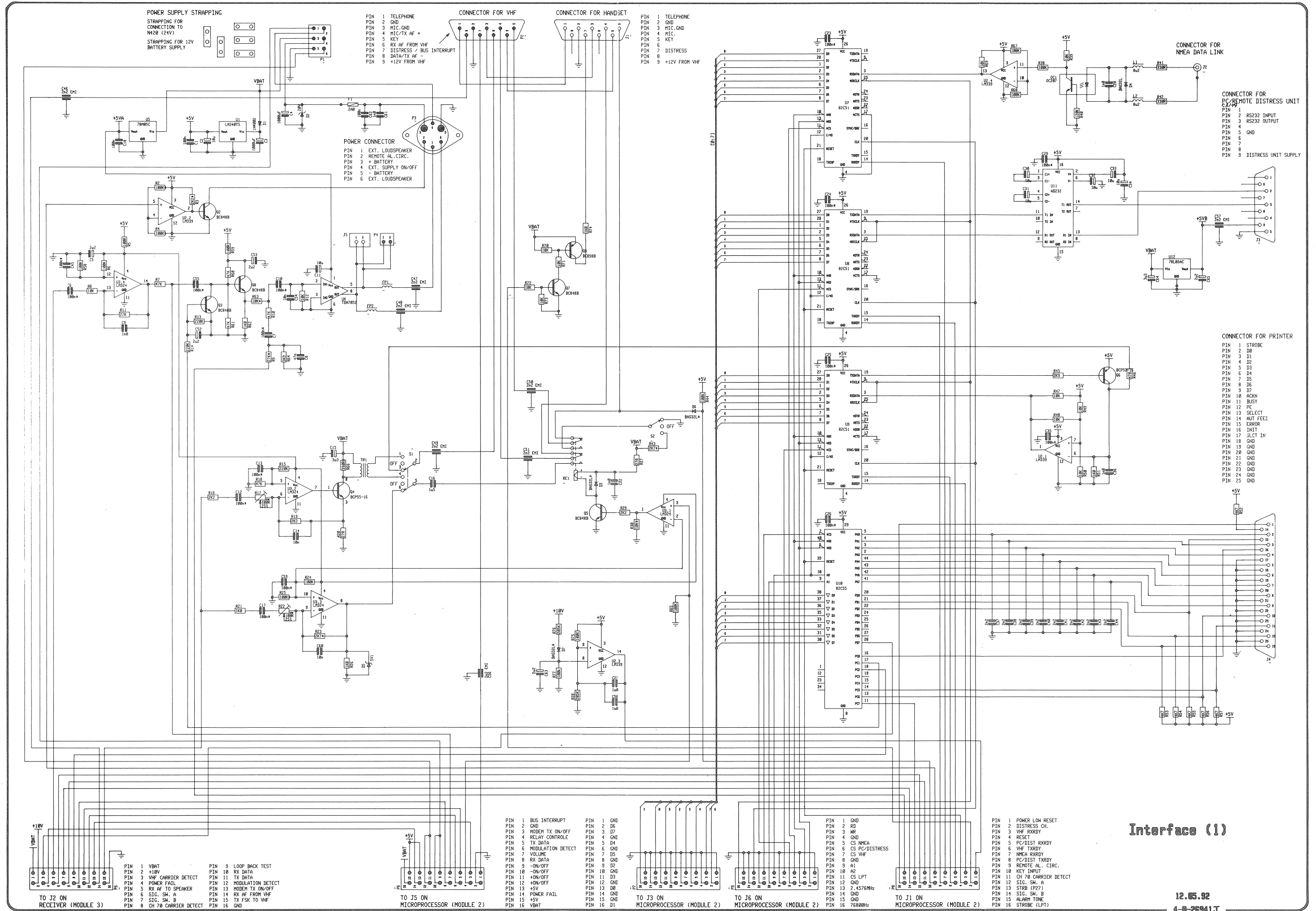

RM2042 4-0-26941 J

Interface (1)

12.85.92  
4-0-26941 J



## 5.2. MICROPROCESSOR (MODULE 2)

The microprocessor module contains a micro computer, build round a general purpose microprocessor with its basic external control logic, memory banks and timers. Furthermore the microprocessor module contains a synchronus receiver, and three 8 bit ports.

### MICROPROCESSOR UNIT

The microprocessor unit U6 is a 16 bit MC68HC000 general purpose microprocessor.

### 8.000 MHz OSCILLATOR

The 8 MHz oscillator is build as a gate oscillator round U16, with the crystal X1 to control the oscillation frequency. The output is used as clock input to the microprocessor U6.

### CONTROL LOGIC

The control logic consist of three major blocks. A reset circuit, a DTACK and VPA generator, and interrupt control logic.

The reset circuit build round U13.3 is used to insure correct initialization of the microprocessor during power-on. The microprocessors RESET and HALT inputs must be kept at a logical low level for at least 100 ms, after Vcc has reached 5V. If this fails the microprocessor goes into a double bus fault state and halts (HALT pin is low while RESET is high). R3 and C14 determines the power-on reset time constant.

The microprocessor uses an asynchronus databus to communicate with all peripherals. This means that the peripherals have to supply the data acknowledge signal (DTACK) to the microprocessor in order to tell when they have finished reading the databus, or when data placed on the bus by the peripherals is valid. If a peripheral does not assert the DTACK signal, the microprocessor will continue to insert wait-states, or ultimately issue a bus error and halt the system.

The used memory and peripheral devices do not have an acknowledge signal. The DTACK is instead generated by the binary counter U14, controlled by the 8 MHz clock and the upper and lower data strobes (UDS and LDS) on the microprocessor. When U14-CT1 is used as output, the microprocessor inserts 1 wait-state in each read/write cycle. This means that the maximum access time for the memory chips and peripheral devices are 250 ns.

One device, i.e. the LCD dot-matrix display, uses a 1 $\mu$ s bus cycle which is equivalent to the bus cycle used by M6800 devices. The M6800 bus cycle is supported by the MC68HC000 microprocessor if the VPA (valid peripheral address) signal is asserted instead of the DTACK signal. This is done each time the display is accessed, by gating output no. 7 on U24, i.e. the displays chip select, back to the VPA input on the microprocessor (via U10.5, U9.3 and U10.1), and at the same time use it to inhibit the generation of DTACK (U9.4, pin 12 is at a logic high level).

The interrupt logic consists of U17 that encodes the interrupts, and U23 that clears the presently served interrupt. A logical low input to U17 indicates that an interrupt needs to be served. The microprocessors interrupt decoder is level sensitive, but inputs to U17 is latched on D-type Flip-Flops, in order to make the interrupts from the peripheral devices edge triggered instead of level triggered.

The interrupt source, i.e. the D-type Flip-Flop that has latched the interrupt signal, is cleared during an interrupt acknowledge cycle. The interrupt acknowledge cycle is recognized when the microprocessors function code outputs (FC0 - FC3) are high. In order to tell the microprocessor that the interrupt acknowledge cycle has been recognized, the VPA signal must be asserted. An interrupt acknowledge cycle is under execution when output from U11.2 is high, this output is gated to the microprocessor in order to assert VPA.

## 5.2. MICROPROCESSOR cont.:

### CIRCUIT SELECT DECODER

All peripheral devices are memory mapped, and can therefore be recognized by their address/addresses in the systems address space. By using address lines A16 to A19 as input to U24, a 4 to 16 line decoder, the address space is divided into 16 64 kbytes pages. Each output 0 to 15 on U24 selects a single 64 kbytes memory page. Each peripheral device is placed on the start address of a new 64 kbytes memory page, and the 16 outputs on U24 is therefore used to chip select the various peripheral devices.

As described above, the display uses an M6800 device bus cycle instead of the normal M68HC000 bus cycle. The display is, contrary to the other peripheral devices, not equipped with a chip select pin. The chip select (output no. 7 on U24) is instead used to generate a VPA (valid peripheral device) signal. When the microprocessor has detected the VPA input, it asserts the VMA (valid memory address) output. This output is gated through U11.2 along with the E output from the microprocessor and the display chip select output from U24, to form the correct enable pulse E (J4 pin 17) to chip select the display.

### EPROM MEMORY

The two IC's U3 and U5 contains the executable program code used by the microprocessor. Since they occupy 128 kbytes, equal to two 64 kbytes memory pages, the IC's are selected when either output 0 or output 1 on U24 are at a logical low level.

### RAM MEMORY

The two IC's U2 and U4 are used to store intermediate and volatile values used by the microprocessor.

### EEPROM MEMORY

The IC U1 is the programmable non-volatile memory. The non-volatile memory is used for storing identification numbers, setup, quick call numbers, station register and received distress messages.

### PROGRAMMABLE TIMERS

U27 contains 3 programmable 16 bit timers. These timers are used to interrupt and hereby control the real time operation of the microprocessor. OUT0 interrupts with an interval of approx. 13 ms. This timer is however under continuous software control and the time interval cannot be found to be stabile. OUT1 is an approx. 1 ms interrupt source. This timer is not under software control and should be stabile.

### REAL-TIME CLOCK

U31 is a battery backed real-time clock. The IC maintains track of time and date. The time is controlled by a 32.768 kHz crystal. The IC interrupts the microprocessor each 10 ms by means of the INTR output. For reference, the 32.768 kHz is output on pin 16 (MFO). The oscillation frequency can be adjusted to the nominal value by use of C39. When RM2042 is turned on, and a message appears, telling that the time has stopped running, the battery may be extinct, and has to be replaced.

### I/O PORTS

The port IC U22 contains three 8 bit parallel ports, which is used to scan the keyboard, and to control the various hardware settings in the the system.

Input pin PA0 is used for setting service mode. A low level input sets RM2042 in service mode.

Input pins PA1 - PA7 and output pins PC4 - PC7 are used to scan the 7x4 keyboard matrix. A logical low pulse on an input pin means a key is currently being pressed.

Output pin PB0 controls the keyboard light. A logical high turns the keyboard light on, and a logical low turns the keyboard light off.

## 5.2. MICROPROCESSOR cont.:

Output pins PB1 and PB3 are used to control the signal switch unit on the receiver module.

A logical high output on pin PB2 is used to tell the scrambler CRY2001 that the connected VHF is on channel 16.

Output pin PB4 is used to control a remote alarm circuit.

Output pin PB5 is used to control the relay on the interface module.

Output pin PB6 is used to control output from the synchronus transmitter U26, and the modem IC on the receiver module. A logic low level starts the transmission, and a logical high level ends the transmission.

Output pin PB7 is used to control the generation of alarm tones by U21.1. A logical low disables, and a logical high enables the output from U21.1.

Input pin PC0 is used to determine the status of the key input from the PTT.

Input pin PC1 is used to determine the status of the carrier detect.

Input pin PC2 is the serial bus interrupt request from the connected VHF.

Input pin PC3 is a signal from the power fail circuit, telling that VBAT is dropping below 10V.

### 4.9152 MHz OSCILLATOR WITH DIVIDER

The 4.9152 MHz oscillator is build as a gate oscillator around U16, with the crystal X2 to control the oscillation frequency. The oscillator is used as a reference clock for the divider that generates baud rates for synchronus and asynchronus communication.

### PRINTER STROBE GENERATOR

When the STRB(P27) signal from the interface module goes low, U14.2 generates, after delay of 2 $\mu$ s, a 4 $\mu$ s logic low strobe pulse to the printer (STROBE (LPT)).

### MODEM COMMUNICATION INTERFACE

The modem communication interface U26, is a synchronus 1200 baud receiver/transmitter. The receiver is controlled by a an external SYNC signal, and a synchronus sampling clock. The SYNC signal is the MODULATION DETECT signal from the channel-70 receiver. When this signal goes high, and the first high going edge on RXDATA is detected, the synchronus receiver clock is started and RXDATA is sampled. Each bit is sampled 8 times (RXCLX is 9600 Hz), and whenever one bit is received, RXRDY goes high, and the microprocessor is interrupted. Data is then fetched by the microprocessor, for further processing.

U26 converts data it receives via the parallel data bus to serial data. The data is output on TXDATA, if/ when the CTS input pin is low. Whenever the U26 is ready to send another byte, TXRDY goes high and interrupts the microprocessor. If the microprocessor has more data to send, another byte is written to U26. Transmission is disabled by setting the CTS input high.

### VOLTAGE CONVERTER

The voltage converter U32 is used to generate -5V from the +5V supply. The -5V is used to control the view angle of the lcd dot-matrix display.

### KEYBOARD LIGHT ON/OFF

The two transistors Q2 and Q3 are used to control the keyboard light. When PB0 on U22 is high Q2 and Q3 is on, and VBAT is supplied to the LED's on the keyboard module.







## 5.2. COMPONENT LOCATION MICROPROCESSOR (MODULE 2)

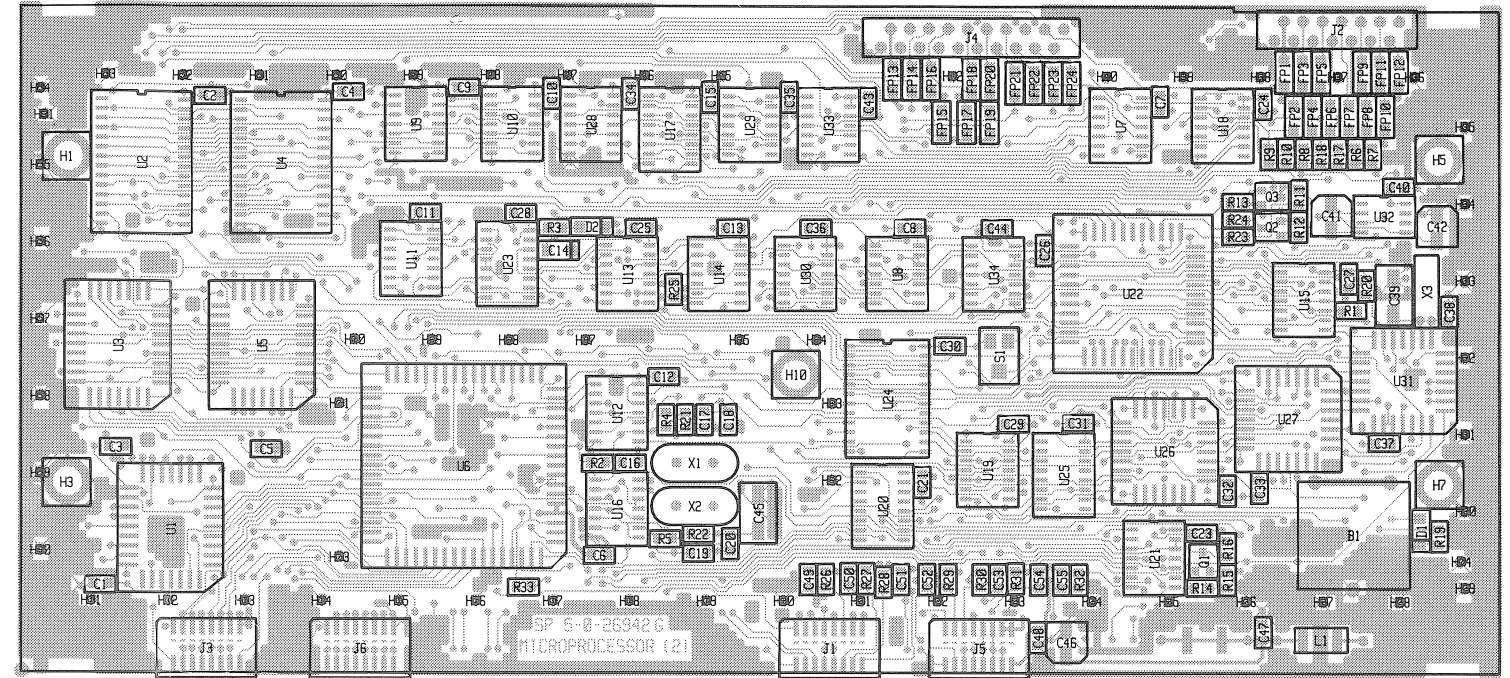

Seen from component side with upper side tracks.

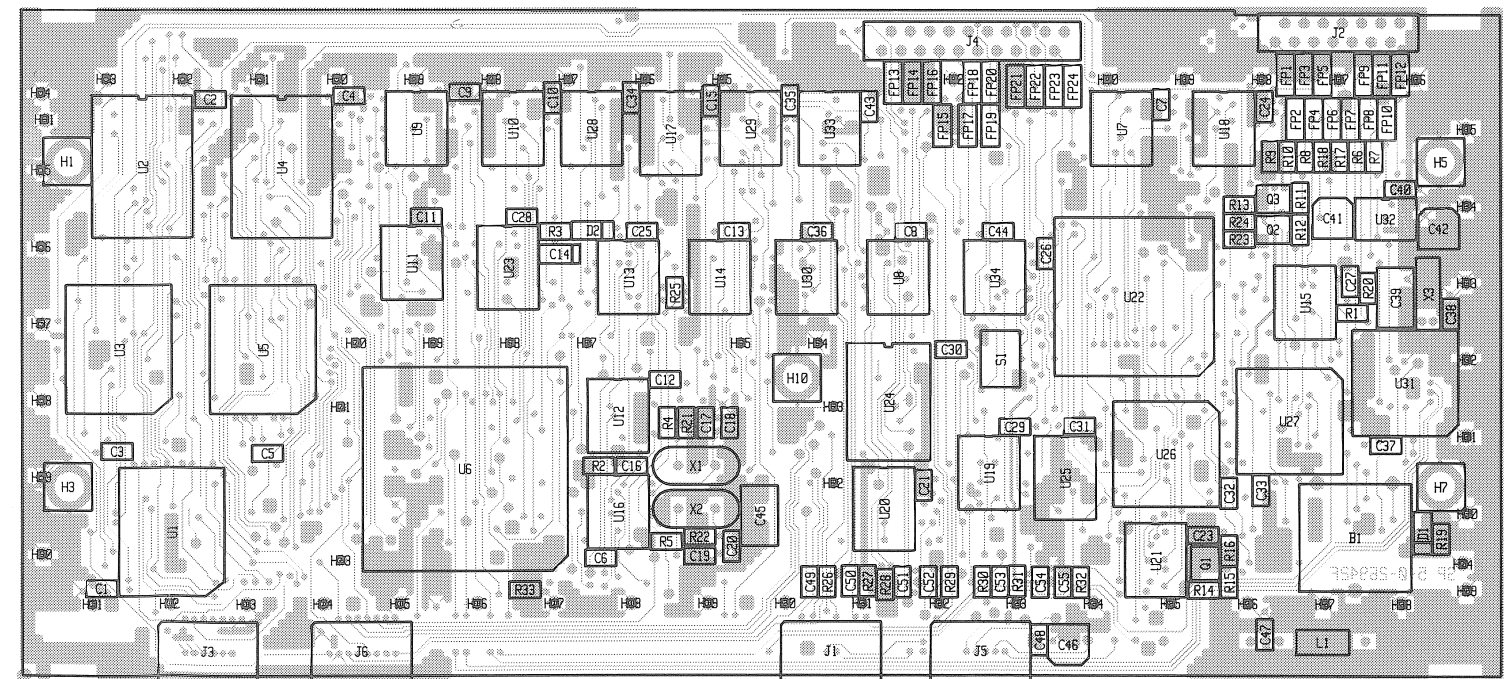

Seen from component side with lower side tracks.

5.2. MICROPROCESSOR (MODULE 2)

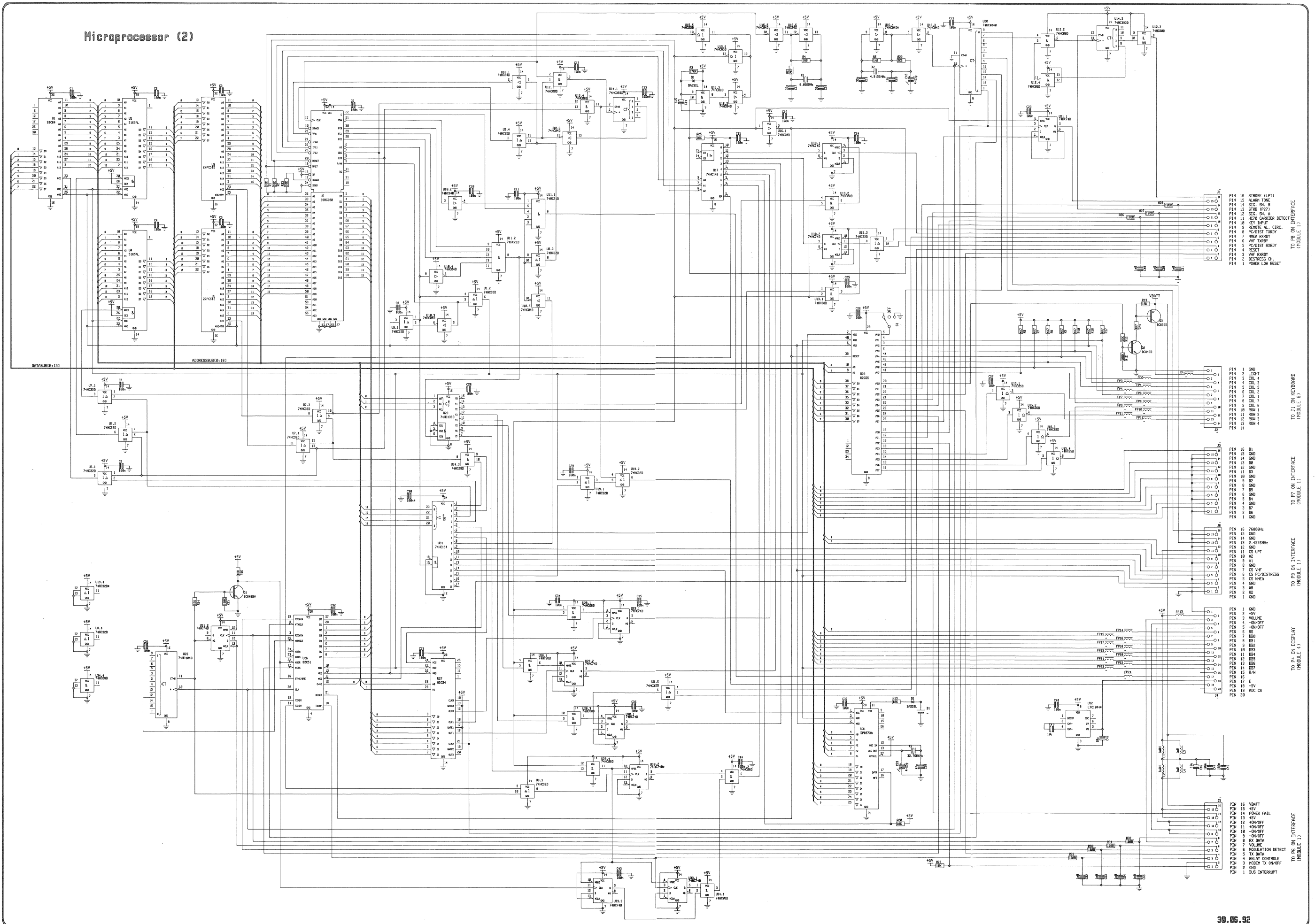

RM2042 4-0-26942G

- PIN 15 STROBE (LPT1)
- PIN 14 ALARM TONE
- PIN 13 SIG. SH. B
- PIN 12 SIG. SH. A
- PIN 11 M78 CARTRIDGE DETECT
- PIN 10 KEY INPUT
- PIN 9 REMOTE AL. CIRC.
- PIN 8 POSITIVE TRIGGER
- PIN 7 M78A ROXSY
- PIN 6 VHF TROUBLE
- PIN 5 POSITIVE EXIBIT
- PIN 4 RESCUE
- PIN 3 VHF EXIBIT
- PIN 2 DISTRESS CH.
- PIN 1 POWER LOW RESET

- PIN 1 GND
- PIN 2 LIGHT
- PIN 3 COL. 4
- PIN 4 COL. 3
- PIN 5 COL. 5
- PIN 6 COL. 1
- PIN 7 COL. 2
- PIN 8 COL. 7
- PIN 9 ROW 1
- PIN 10 ROW 2
- PIN 11 ROW 3
- PIN 12 ROW 4
- PIN 14 GND

- PIN 16 GND
- PIN 15 GND
- PIN 14 GND
- PIN 13 GND
- PIN 12 GND
- PIN 11 GND
- PIN 10 GND
- PIN 9 GND
- PIN 8 GND
- PIN 7 GND
- PIN 6 GND
- PIN 5 GND
- PIN 4 GND
- PIN 3 GND
- PIN 2 GND
- PIN 1 GND

- PIN 16 75800Hz
- PIN 15 GND
- PIN 14 GND
- PIN 13 4.53MHz
- PIN 12 GND
- PIN 11 CS LPT
- PIN 10 GND
- PIN 9 GND
- PIN 8 VHF
- PIN 7 CS VHF
- PIN 6 CS DISTRESS
- PIN 5 CS M78A
- PIN 4 M78
- PIN 3 M78
- PIN 2 GND
- PIN 1 GND

- PIN 1 GND
- PIN 2 45V
- PIN 3 VOLUME
- PIN 4 ON/OFF
- PIN 5 ON/OFF
- PIN 6 RS
- PIN 7 RS
- PIN 8 RS
- PIN 9 RS
- PIN 10 RS
- PIN 11 RS
- PIN 12 RS
- PIN 13 RS
- PIN 14 RS
- PIN 15 RS
- PIN 16 RS
- PIN 17 C
- PIN 18 VHF
- PIN 19 ADC CS
- PIN 20 GND

- PIN 15 VBAT
- PIN 14 45V
- PIN 13 45V
- PIN 12 45V
- PIN 11 ON/OFF
- PIN 10 ON/OFF
- PIN 9 ON/OFF
- PIN 8 RX DATA
- PIN 7 VOLUME
- PIN 6 MODULATION DETECT
- PIN 5 TX DATA
- PIN 4 RELAY CONTROL
- PIN 3 MODER TX ON/OFF
- PIN 2 GND
- PIN 1 BUS INTERRUPT

- PIN 15 VBAT
- PIN 14 45V
- PIN 13 45V
- PIN 12 45V
- PIN 11 ON/OFF
- PIN 10 ON/OFF
- PIN 9 ON/OFF
- PIN 8 RX DATA
- PIN 7 VOLUME
- PIN 6 MODULATION DETECT
- PIN 5 TX DATA
- PIN 4 RELAY CONTROL
- PIN 3 MODER TX ON/OFF
- PIN 2 GND
- PIN 1 BUS INTERRUPT

- PIN 15 VBAT
- PIN 14 45V
- PIN 13 45V
- PIN 12 45V
- PIN 11 ON/OFF
- PIN 10 ON/OFF
- PIN 9 ON/OFF
- PIN 8 RX DATA
- PIN 7 VOLUME
- PIN 6 MODULATION DETECT
- PIN 5 TX DATA
- PIN 4 RELAY CONTROL
- PIN 3 MODER TX ON/OFF
- PIN 2 GND
- PIN 1 BUS INTERRUPT

- PIN 15 VBAT
- PIN 14 45V
- PIN 13 45V
- PIN 12 45V
- PIN 11 ON/OFF
- PIN 10 ON/OFF
- PIN 9 ON/OFF
- PIN 8 RX DATA
- PIN 7 VOLUME
- PIN 6 MODULATION DETECT
- PIN 5 TX DATA
- PIN 4 RELAY CONTROL
- PIN 3 MODER TX ON/OFF
- PIN 2 GND
- PIN 1 BUS INTERRUPT



### 5.3. RECEIVER (MODULE 3)

The receiver module contains a fully channel-70 receiver, FSK decoder/encoder, switches and control logic for automatically change over between the built-in channel-70 receiver and the connected VHF radiotelephone.

The block diagram of the built-in channel-70 receiver is shown below. This receiver is constructed in accordance with the double super heterodyne principle, which is characterized by having two intermediate frequencies. The input signal to the receiver, which is an FM signal, is received by means of a separate antenna connected directly to the RM2042.

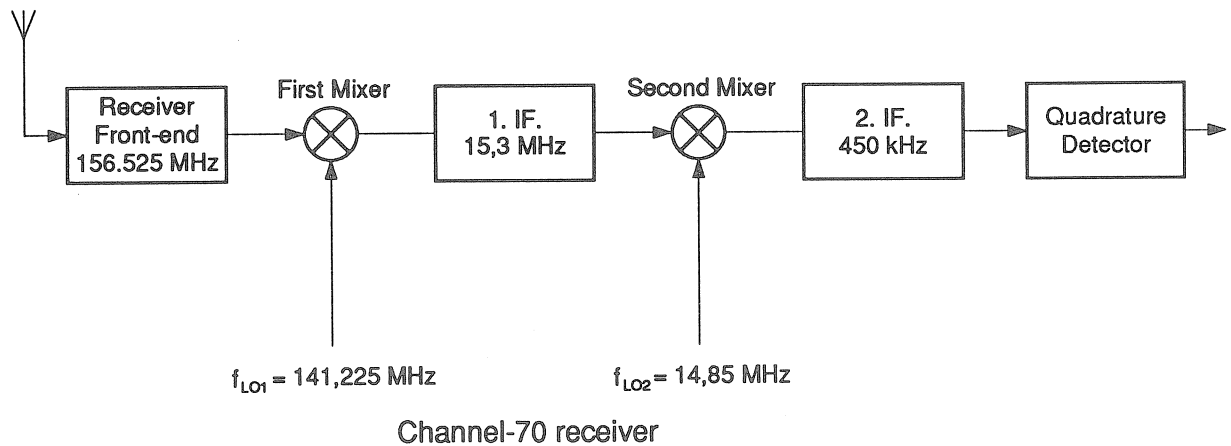

#### RECEIVER FRONT-END

The receiver front-end is tuned to channel 70 (i.e. 156.525 MHz) and consists of the low noise dual gate MOSFET transistor Q1 surrounded by two double tuned bandpass filters with high quality factor Q.

From the antenna the signal is led to the input bandpass filter, which consists of two resonance circuits, which are critically coupled to each other by the series connection of the two capacitors C2 and C3.

The two resonance circuits are tuned by the two adjustable coils L1 and L2 and have a total bandwidth of about 10 MHz. The two diodes D1 and D2 are located in the second section of the input bandpass filter to protect the RF-amplifier from damage by high voltages.

The configuration of the intermediate filter at the output of the RF-amplifier is identical to the input bandpass filter. The intermediate filter is tuned by the two adjustable coils L3 and L4 and has a bandwidth of about 4 MHz.

The front-end selectivity gives the necessary attenuation of unwanted out of band signals, which as an example could be a signal at the image frequency (i.e.  $f_{IM} = 125.925 \text{ MHz}$ ).

#### FIRST MIXER

The first mixer is a balanced active J-FET mixer with good large signal properties and low noise factor. The signal from the receiver front-end is led through the unbalanced to balanced transformer TR1 to the gates of the two J-FET's Q2 and Q3. These J-FET's are switched by injecting the 1st. LO signal to the sources and a multiplex of the RF- and LO-signal is then generated. This new signal is led to the output transformer TR2, where the wanted signal at the first intermediate frequency at 15.3 MHz is selected by the tuned circuit consisting of TR2 and C24.

### 5.3. RECEIVER (MODULE 3) cont.:

#### FIRST LOCAL OSCILLATOR

The first local oscillator is generating the injection signal at 141.225 MHz to the first mixer. The oscillator is crystal controlled and is oscillating directly at the wanted LO frequency.

The crystal X3 is constructed to work at the 7th. overtone and is used in a series resonance mode. Unfortunately the crystal has also a parallel resonance frequency, which is located only 4 to 5 kHz above the wanted series resonance. This parallel resonance frequency is determined by the static capacitance  $C_0$  and is effecting the phase response of the crystal in an unwanted maner, which is lowering the tracking range. To overcome this problem, the crystal is parallel connected with the inductor L9, which partly is eliminating the static capacitance.

The oscillator is build-up around the bipolar NPN transistor Q5, which has a typical transition frequency  $f_t$  of 5 GHz. The transistor is used in a commen base configuration, where the capacitor C79 is used to ground the signal at the base terminale.

The oscillation is obtained by feeding back the collector signal to the emitter, where the crystal is used as the feed back element. The adjustable coil L6 at the collector form a resonance circuit together with the series connection of the capacitors C80, C81 and C82. The oscillation frequency can be adjusted by tuning the resonance frequency of this tank circuit, which will increase or decrease the phase shift in the open loop response.

The oscillator is followed by two buffers - an oscillator buffer and an LO buffer.

To minimize the capacitive loading of the oscillator, the output signal is taped across a relative large capacitor of 56pF. The taped signal is buffered by the transistor Q6, which is working as an emitter follower. The output signal from Q6 is loaded with a resistor of  $47\Omega$ , which will camouflage the capacitive loading by the input of the LO buffer and then stabilize the oscillator buffer at higher frequencies.

In the LO buffer, the signal is amplified to give an output level of 7 dBm into  $50\Omega$ . The LO buffer is build-up around the transistor Q7, which is used in a commen emitter configuration. By means of the two capacitors C89 and C90, the output impedance is matched to the mixer input of about  $170\Omega$ .

#### CRYSTAL FILTER AND FIRST IF BUFFER AMPLIFIER

The receiver adjacent channel selectivity is obtained by means of the crystal filter FL1 at the 1st. IF and the ceramic filter FL2 at the 2nd. IF.

The input and output of the crystal filter is impedance matched to 3k, which is obtained by means of the resistors R13, R14, R15 and R16.

From the 1st. mixer, the signal is led through the crystal filter to the input of the 2nd. IF buffer amplifier. This amplifier is build-up around the dual gate MOSFET transistor Q4, which has a tuned drain circuit consisting of the inductor L5 and the capacitors C29 and C31.

#### SECOND MIXER & LO, CERAMIC FILTER, FM-DETECTOR AND AF AMPLIFIER

The 2nd. mixer and LO, FM-detector and AF amplifier are all included in the integreted circuit U1, which is of the type MC3372.

From the 1st. IF buffer amplifier, the signal is led to the 2nd. mixer, where it is mixed with LO2.

The second local oscillator frequency is crystal controlled and is tuned to 14.85 MHz by the trimming capacitor C34. The LO2 signal is generated by a build-in bipolar NPN transistor, which form a colpitts oscillator by means of the crystal X1 and four external capacitors.

The output of the 2nd. mixer is led to the ceramic filter FL2, which is centered at 450 kHz. The 2nd. IF signal is then amplified by the limiting IF amplifier, that approximately has a gain of 92 dB.

The signal is detected by the build-in quadrature detector, which use an external capacitor and ceramic resonator as the  $90^\circ$  phase shift network.

After detection, the signal is amplified by the build-in AF amplifier, and the carrier component at 450 kHz is removed by means of the resistor R38 and the capacitor C51. The output level from the following de-emphasis filter is adjusted by the trimming resistor R66 to 250 mV with an input carrier modulated with 1 kHz to give a peak frequency deviation of 3 kHz.

As an extra facillity, the MC3372 has a level meter output, which in this design only is used to adjust the front-end filters. The level meter output is formed as a current generator, that produce a DC-current proportional to the carrier level measured in dBm. The current is transformed to a voltage by means of the resistor R27 and is filtered by the capacitor C43.

### 5.3. RECEIVER (MODULE 3) cont.:

#### AF FILTERS

The output signal from the AF amplifier inside U1 is led through the MOSFET switch U6 to the de-emphasis filter, which is build-up around the operational amplifier U3.1. This filter is implemented as a second order band pass filter with a center frequency at 950 Hz.

An exact copy of this de-emphasis filter, with the same component values, is used in the receiver signal path from the connected VHF radiotelephone. This filter is build-up around the operational amplifier U7.3.

The signals from the build-in channel-70 receiver and the connected VHF radiotelephone are led to the input of the second switch inside U6, where the signal selection is performed.

The selected signal is filtered by a 6th. order Gaussian high pass filter with a cutoff frequency of about 1 kHz followed by a 4th. order Chebychev low pass filter with a cutoff frequency of about 3 kHz. These filters are all together optimized with respect to stopband attenuation and group delay distortion.

The 6th. order Gaussian filter is realized as an infinite-gain multiple-feedback filter and is build-up around the three operational amplifiers U3.2, U3.3 and U3.4.

The 4th. order Chebychev filter is realized as a voltage controlled voltage source filter (VCVS filter) and is build-up around the two operational amplifiers U8.3 and U8.4.

The output signal from the 4th. order Chebychev filter is led to the voltage divider consisting of R112 and R113, where the signal level is attenuated to about  $10\text{mV}_{\text{RMS}}$ . This signal is used as input to the FSK decoder.

#### FSK DECODER/ENCODER

The FSK (Frequency-Shift Keying) decoder and encoder is integreted in U2, which is a 1200 baud SINGLE CHIP MODEM of type MSM6927 from the manufacturer OKI.

#### FSK decoder

The FSK decoder consist of receive filter, FSK demodulator and AF signal detect circuit.

The receive filter is a 12th. order band pass filter with a lower cutoff frequency at 600 Hz and an upper cutoff frequency at 2700 Hz, which gives a bandwidth of 2.1 kHz.

The AF signal detect circuit consist of an AC to DC converter, that produce a DC-voltage proportional to the input signal level. This DC-voltage is compared with a reference voltage, which can be modified by changing the voltage divider consisting of the two resistors R64 and R65. The output of this comparator is led to pin 12 (CD1) at U2, which will be logical low, if an AF signal is detected.

The bit stream output from the FSK demodulator is available at pin 10 (RD), but the output will be kept logical high, if no AF signal is detected.

#### FSK encoder

The FSK encoder consist of FSK modulator and transmit filter.

The bit stream input to the FSK modulator is led to pin 9 (XD) and to enable the FSK modulator, the REQUEST TO SEND signal (RS1) at pin 4 must be logical low. The FSK modulator is generating a tone signal, where the frequency is altered between 1300 Hz (mark = '1') and 2100 Hz (space = '0') in accordance with the input bit stream. The frequency of the mark and space signals is controlled by the crystal X2, which is working at 3.5795 MHz.

The generated FSK signal is led through the transmit filter to the analog output (Aout) at pin 34. The output signal is then led to the external transmit filter, which is a 2nd. order Chebychev low pass filter with 0.1 dB ripple and a cutoff frequency of 3.9 kHz. This filter is build around the operational amplifier U7.4 and the output level is 0 dBm ( $600\Omega$ )  $\pm 2$  db.



### 5.3. RECEIVER (MODULE 3) cont.:

#### SIGNAL SWITCHES AND CONTROL LOGIC

The receiver module contains two analog switches, which are included in the CMOS-IC U6. The first switch is only used for loop back test purpose and is controlled by the microprocessor. The second switch is used for switching between the build-in channel-70 receiver and the connected VHF radiotelephone. This switch is controlled by the logical signal Q, which is generated by combining the output of the channel-70 carrier detect circuit and the two logic signals A and B. The function of the signal switches and the corresponding control logic is described by the block diagram below, which also include the logical circuits used to generate the CH70 CARRIER DETECT, VHF CARRIER DETECT and MODULATION DETECT signals.

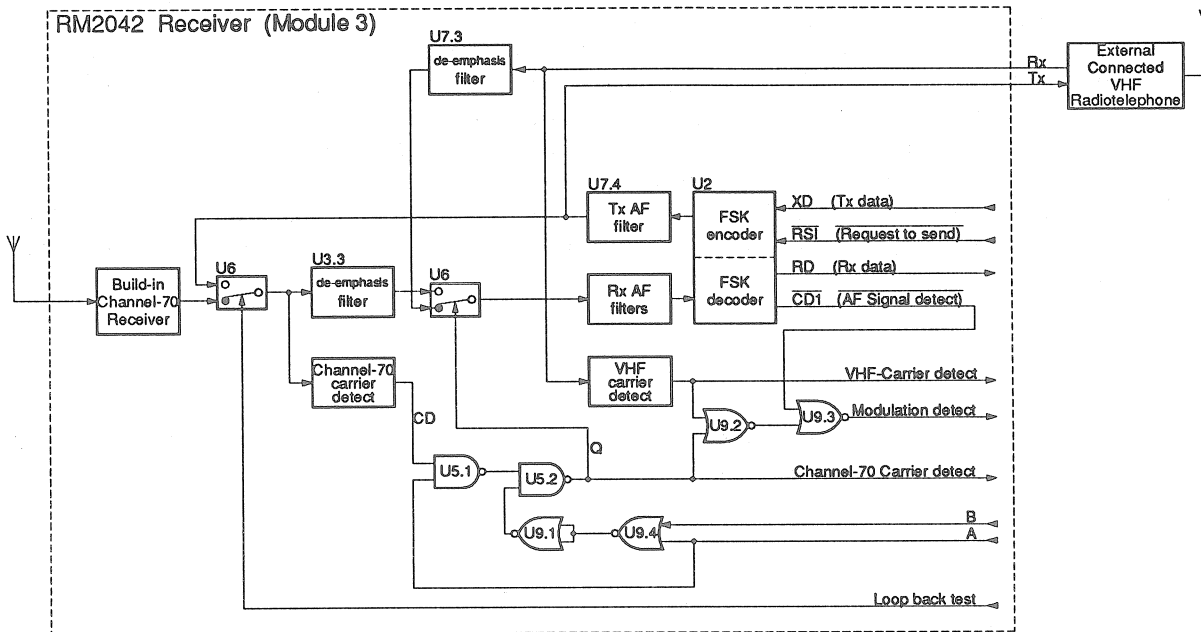

RM2042  
4-0-27542

The truth table for the switch control signal Q is shown below.

NOTE! The signal CD is generated by means of the Channel-70 Carrier Detect circuit and indicate whether a carrier on channel 70 is received (CD = '1' if a carrier is detected and CD = '0' if no carrier is detected).

A	B	Q	REMARKS
0	0	1	CH70 used for Reception of DSC.
0	1	0	VHF used for reception of DSC.
1	0	CD	VHF used as default for reception of DSC, but CH70 used instead if carrier detected.
1	1	CD	

### 5.3. RECEIVER (MODULE 3) cont.:

#### CHANNEL-70 CARRIER DETECT

The receiver module is constructed with two identical carrier detect circuits - one for the build-in channel-70 receiver and one for the external connected VHF radiotelephone.

The carrier detect circuit for the build-in channel-70 receiver is included to avoid emission of a DSC call, while an other unit is transmitting. In addition the CH70 CARRIER DETECT signal is used to generate the MODULATION DETECT signal, which is described later on.

The carrier detect circuit is constructed as an ordinary noise triggered squelch, which in principle is measuring the noise level above the upper frequency component in the information signal.

From the output of the FM detector, the received signal is led to a band pass filter with a center frequency of about 45 kHz, formed by the two operational amplifiers U8.1 and U8.2. The output signal from this filter is rectified by the double diode D4 and the resulting DC voltage is compared to a reference voltage by means of U4.3.

The level of the rectified voltage and thereby the trigger level of the carrier detect circuit can be adjusted by the trimming resistor R36.

If only a noise signal is received, the rectified input signal to the inverting terminal at the voltage comparator will be large enough to keep the output low. But if a carrier is received, the output noise from the FM detector will be reduced and the comparator output will change to logical high.

#### VHF CARRIER DETECT

The VHF carrier detect circuit is used to detect whether a carrier signal is received by the external connected VHF radiotelephone. This information is required to control the termination of a radiotelephone contact on a working channel between a ship station and a cost station. According to the recommendation 689 given by the international organisation CCIR, a radiotelephone contact, which is initiated by a DSC call, shall be considered to be complete, if the ship station equipment detects the absence of the cost station's carrier for a periode greather than 5 seconds.

As mentioned above the VHF carrier detect circuit is identical to the corresponding carrier detect circuit for the build-in channel-70 receiver. The band pass filter is build-up around the two operational amplifiers U7.1 and U7.2, while U4.4 is used as the voltage comparator.

The trigger level of the VHF carrier detect circuit is adjusted by the trimming resistor R93.

#### MODULATION DETECT

To initialize the sampling of the received bit stream, a MODULATION DETECT signal is generated by means of the two NOR gates U9.2 and U9.3. The truth tabel for the MODULATION DETECT signal is given on the following page.

Please note the bar above the signal name: "AF SIGNAL DETECT" in the truth tabel, which is indicating that this signal is inverted.



### 5.3. RECEIVER (MODULE 3) cont.:

CH70 CARRIER DETECT	VHF CARRIER DETECT	$\overline{\text{AF}}$ SIGNAL DETECT	MODULATION DETECT	REMARKS
0	0	0	0	No carrier detected at CH70 receiver, and no carrier detected at ext. VHF. AF signal detected because of noise.
0	0	1	0	Non existing combination.
0	1	0	1	No carrier detected at CH70 receiver, but carrier detected at ext. VHF. AF signal detected from ext. VHF.
0	1	1	0	No carrier detected at CH70 receiver, but carrier detected at ext. VHF. No AF signal detected from ext. VHF.
1	0	0	1	Carrier detected at CH70 receiver, and no carrier detected at ext. VHF. AF signal detected from CH70 receiver.
1	0	1	0	Carrier detected at CH70 receiver, and no carrier detected at ext. VHF. No AF signal detected from CH70 receiver.
1	1	0	1	Carrier detected at CH70 receiver, and carrier detected at ext. VHF. AF signal detected from CH70 receiver.
1	1	1	0	Carrier detected at CH70 receiver, and carrier detected at ext. VHF. No AF signal detected from CH70 receiver.

RM2042

#### 5V SUPPLY

The 5V supply is generated from the battery voltage by the series voltage regulator U11. This regulator is of the type 78L05AC, which is able to deliver a current of about 50mA without any heat sink.

#### 10V SUPPLY

The 10V supply is generated from the battery voltage by the series voltage regulator U10, which is of the type LP2951C. The output voltage is determined by four feed back resistors (R121 to R124) and is adjustable by means of the trimming resistor R124. The LP2951C has a build-in facility for generating an error signal, when the output voltage drops more than 5% with respect to the programmed output voltage. This error signal is watch every one milli second by the microprocessor to ensure a controlled power down sequence.



### 5.3. COMPONENT LOCATION RECEIVER (MODULE 3)

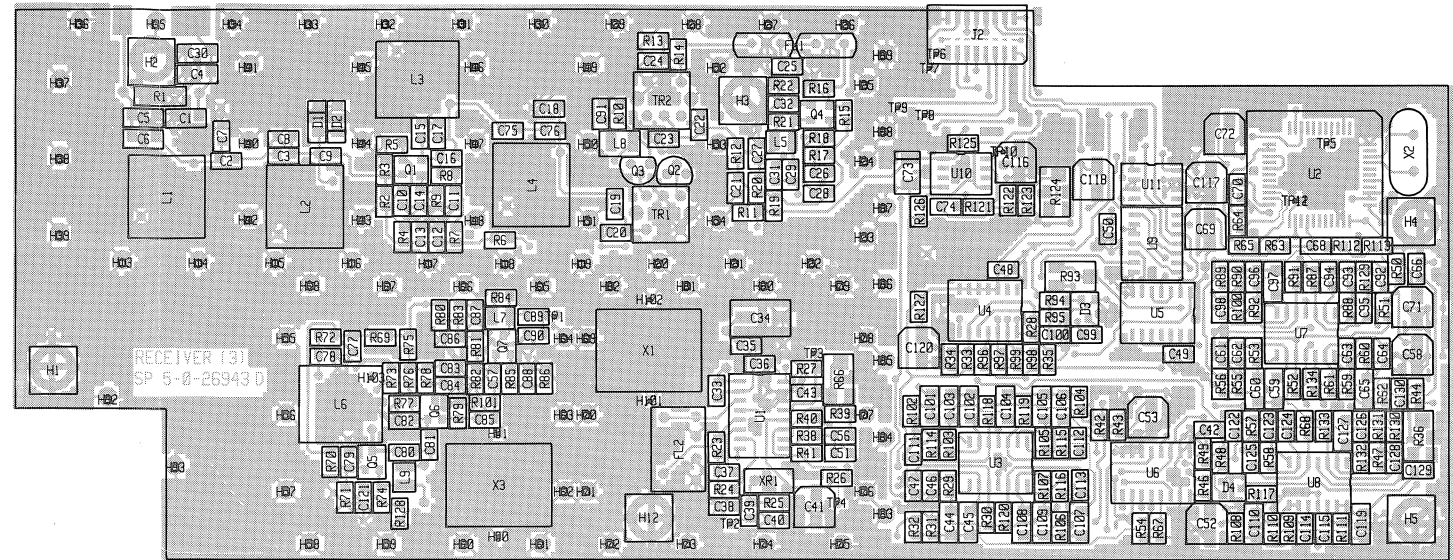

Seen from component side with upper side tracks.

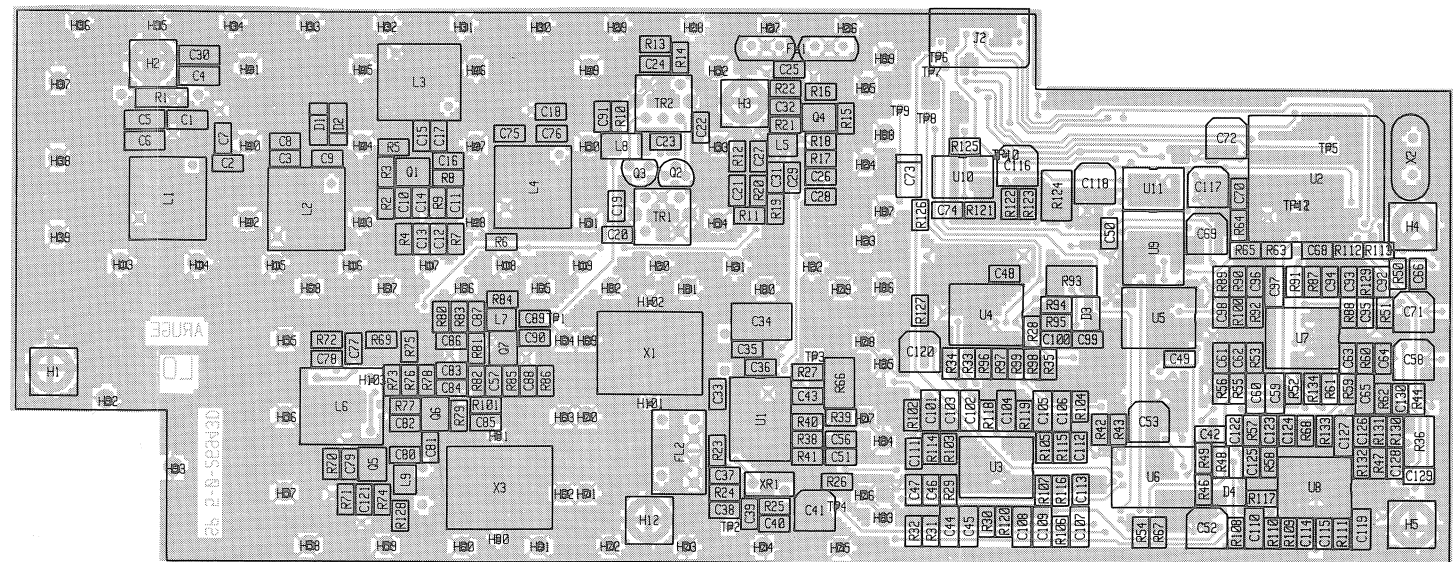

Seen from component side with lower side tracks.

5.3. RECEIVER (MODULE 3)

RM2042 4-0-26943 I

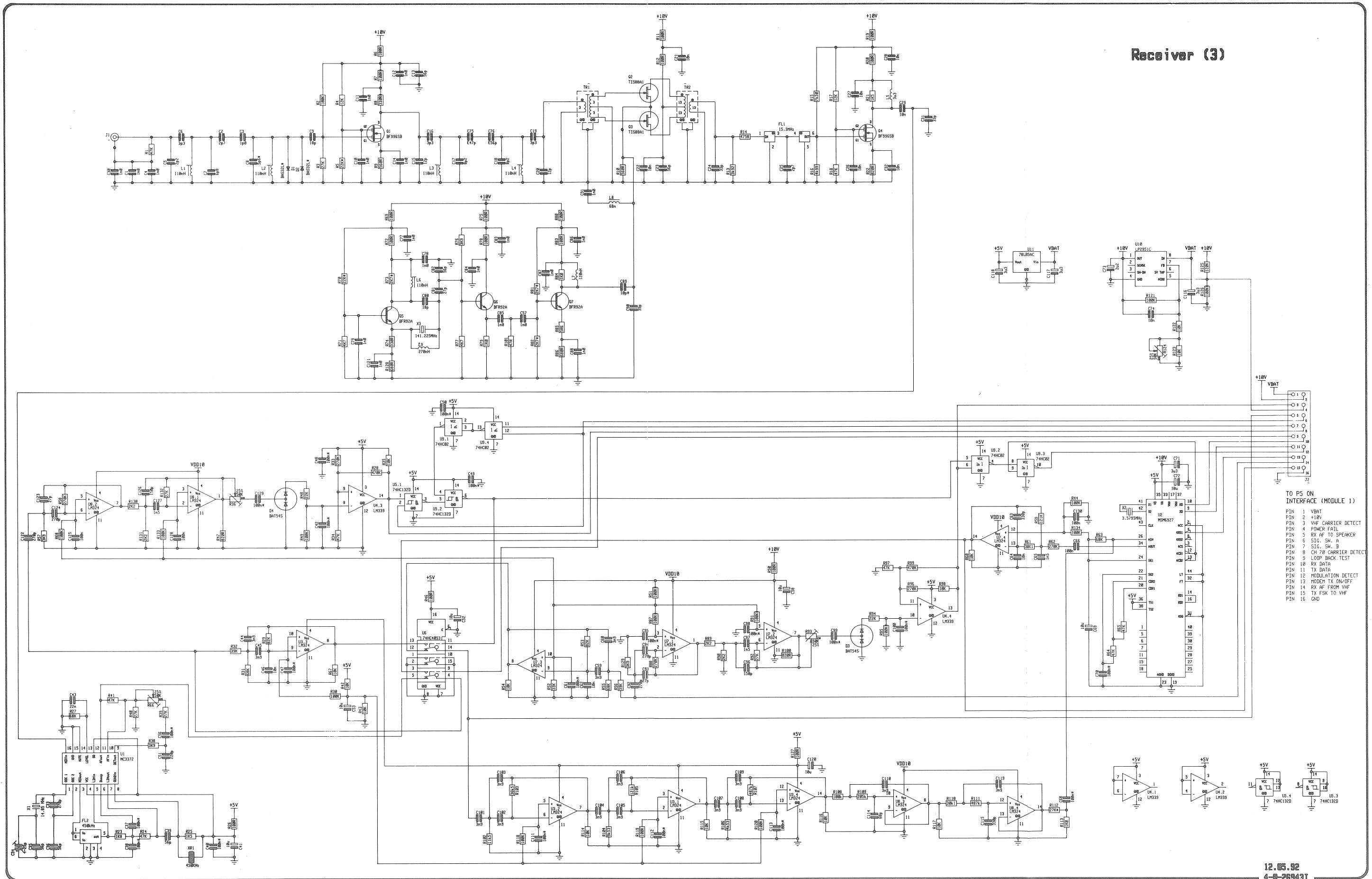

Receiver (3)

- TO P5 ON INTERFACE (MODULE 1)
- PIN 1 VBAT
  - PIN 2 +18V
  - PIN 3 VHF CARRIER DETECT
  - PIN 4 POWER FAIL
  - PIN 5 RX AF TO SPEAKER
  - PIN 6 SIG. SM. A
  - PIN 7 SIG. SM. B
  - PIN 8 CH 70 CARRIER DETECT
  - PIN 9 LOOP BACK TEST
  - PIN 10 RX DATA
  - PIN 11 TX DATA
  - PIN 12 MODULATION DETECT
  - PIN 13 MODM TX ON/OFF
  - PIN 14 RX AF FROM VHF
  - PIN 15 TX FSK TO VHF
  - PIN 16 GND



## 5.4. DISPLAY UNIT (MODULE 4)

An LCD display of 2 times 24 characters with LED backlight is used to read out information to the operator.

### DISPLAY MODULE

The display module is mounted on top of the display unit by means of two connectors and four screws. The display module has a dot matrix LCD display with 2 times 24 characters and a build-in LCD driver controller. This controller has a built-in character generator and a display data RAM. All the display functions are controlled by instructions from the microprocessor.

### DISPLAY INTERFACE

The display is interfaced with the microprocessor (module 2) through the ribbon cable connector P4. The display enable pulse (E signal) is led directly to the LCD display by means of the strap field P5. The delay circuit consisting of four NAND gates (U4) and three buffers (U5) is not used in this product, but nevertheless it is mounted, because the display unit also is used in other of our products.

### BRIGHTNESS CONTROL

Brightness or viewing angle control is performed by a four bit digital to analog converter, which gives 16 steps for regulation.

The D/A converter is build-up around four D-type flip-flops integrated in U1 and the operational amplifier U2.1. The four D-type flip-flops is used as parallel input/output latches and each of the output pins Q1, Q2, Q3 and Q4 are connected through one of the resistors R6, R8, R9 and R10 to the inverting input of U2.1. The output voltage from the D/A converter (i.e. output at U2.1) is divided by 2 by means of two resistors (R16 and R18) and is then led to the non-inverting input at the amplifier U2.4. The inverting input at this amplifier is connected to a resistor network, which include the NTC resistor R12. This circuit compensates for the temperature change of the brightness control voltage.

The output from the amplifier U2.4 is connected to the display brightness control at pin 6 in the connector J1.

### BACKLIGHT CONTROL

The current through the backlight LED's is controlled by the transistor Q1, which again is controlled by the amplifier circuit build-up around U2.2.

The current running in the backlight LED's is also running through the emitter resistors and the voltage across R25 and R28 is therefore a function of the backlight current.

This voltage will almost be equal to the voltage at the non-inverting terminal, because of the relative large voltage gain given by the ratio of R20 to R22.

The voltage at the non-inverting input is only determined by the two flip-flops Q5 and Q6 integrated in U1 and the voltage divider given by the resistors R21, R23 and R24. The current running in the emitter of Q1 can therefore be controlled by combining the digital outputs from U1. This means, that the current running through the backlight LED's can be controlled by U1 in four steps, with step 1 as 0 mA and step 4 as 180 mA.







## 5.4. COMPONENT LOCATION DISPLAY (MODULE 4)

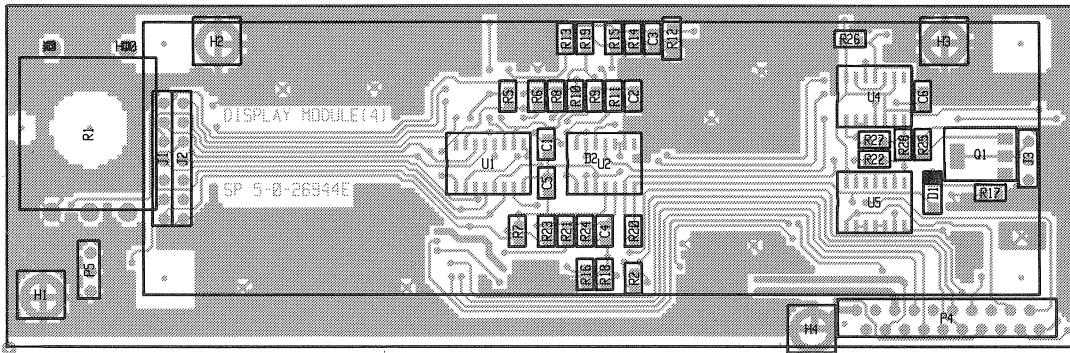

Seen from component side with upper side tracks.

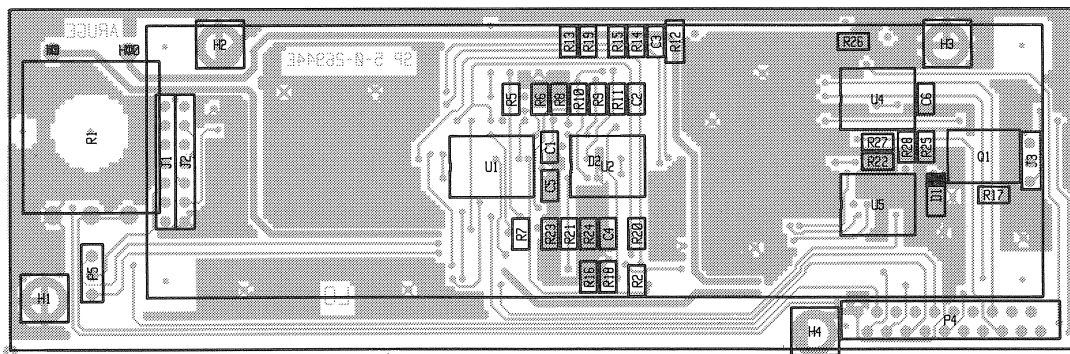

Seen from component side with lower side tracks.

5.4. DISPLAY (MODULE 4)

DISPLAY UNIT (MODULE 4)

FROM MAIN PROCESSOR

- PIN 1 GND
- PIN 2 VCC +5V
- PIN 3 SPEAKER VOL.
- PIN 4 ON/OFF
- PIN 5 ON/OFF
- PIN 6 RS
- PIN 7 DD0
- PIN 8 DD1
- PIN 9 DD2
- PIN 10 DD3
- PIN 11 DD4
- PIN 12 DD5
- PIN 13 DD6
- PIN 14 DD7
- PIN 15 R/W
- PIN 16 DISPCS
- PIN 17 E
- PIN 18 -5V
- PIN 19 D/ACS
- PIN 20 ARDY

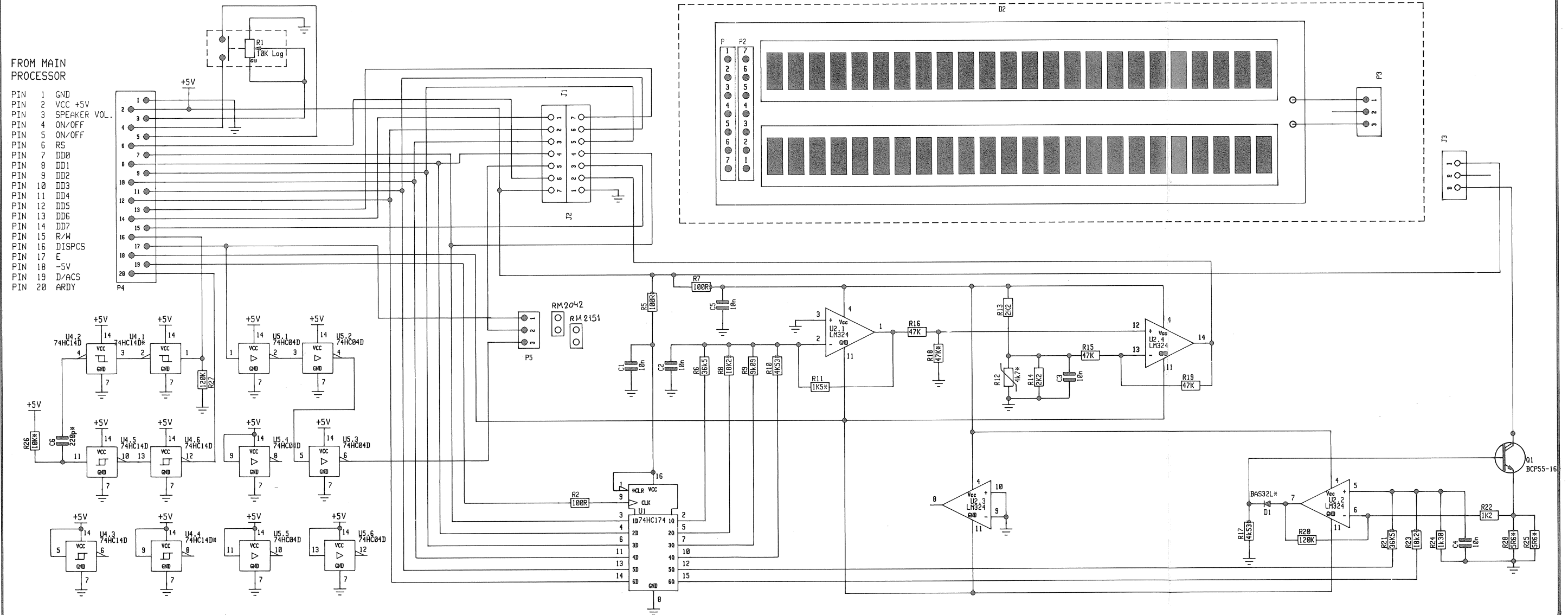

4-0-26944F

RM2042 4-0-26944F



5.5. KEYBOARD (MODULE 5)

The keyboard consist of a 4 times 8 matrix of which 26 keys are used.  
 The 4 rows are set high alternately and by reading the output at the 8 columns it is possible to determine which key has been activated. This scanning of the keyboard takes place 100 times per second.  
 The keyboard can be illuminated by 13 LED's. The voltage across the LED's is controlled by the two transistors Q2 and Q3, placed at the microprocessor (module 2) and the current in each LED is roughly 8.5 mA.

### Keyboard Unit (6)

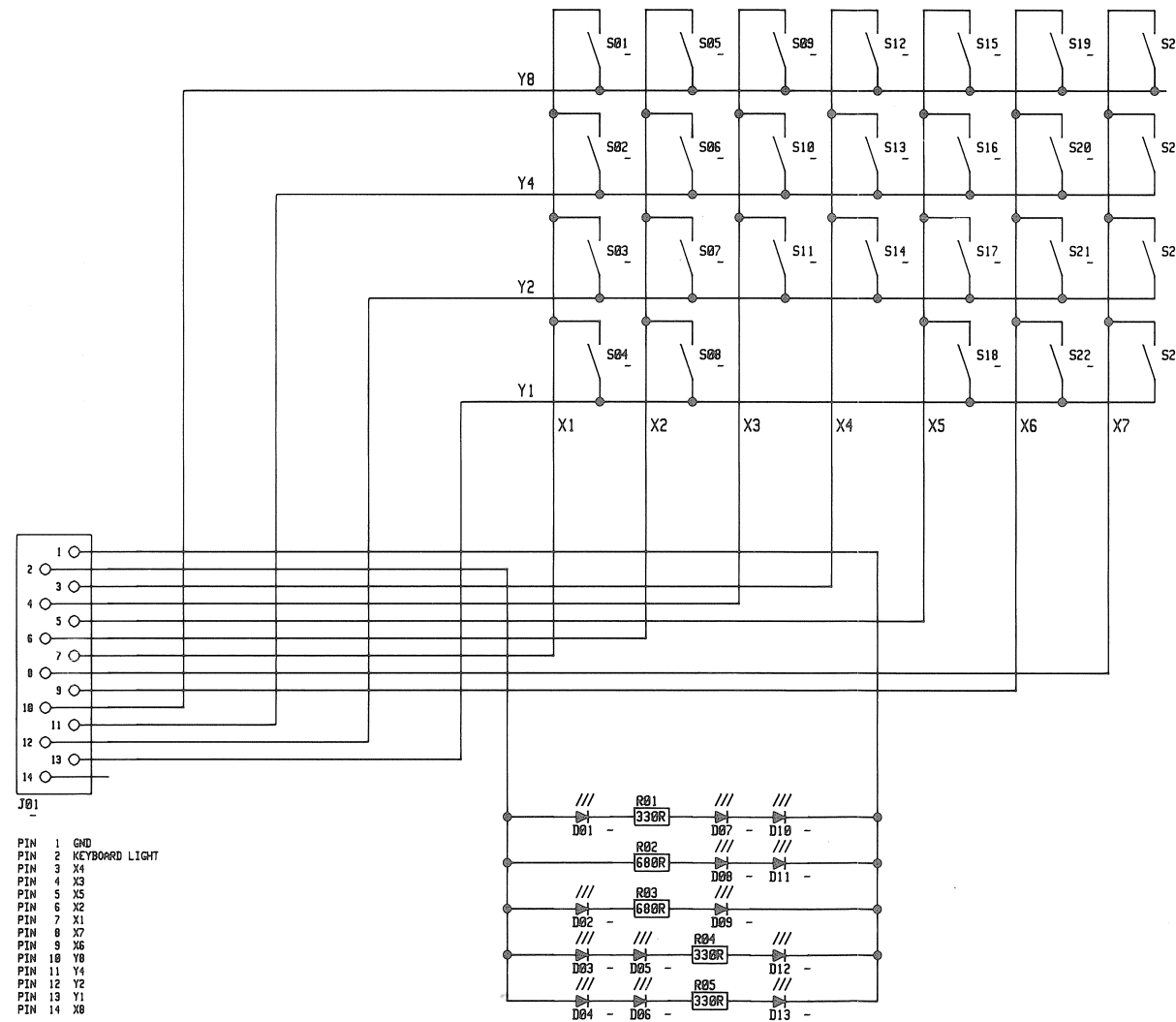

- PIN 1 GND
- PIN 2 KEYBOARD LIGHT
- PIN 3 X4
- PIN 4 X3
- PIN 5 X5
- PIN 6 X2
- PIN 7 X1
- PIN 8 X7
- PIN 9 X6
- PIN 10 Y8
- PIN 11 Y4
- PIN 12 Y2
- PIN 13 Y1
- PIN 14 X0

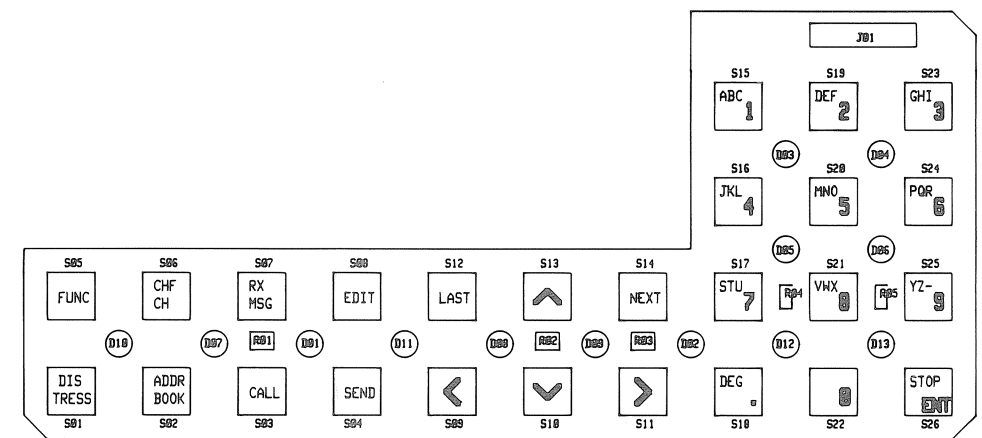



## CONTENTS

- 6. MICROTELEPHONE INSTALLATION
- 6.1. SPECIAL INSTALLATION WITH 2 MICROTELEPHONES
- 6.2. SPECIAL INSTALLATION WITH 3 MICROTELEPHONES



## 6. MICROTELEPHONE INSTALLATION

VHF RT2047

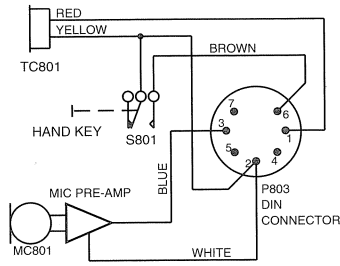

SCRAMBLER CRY2001, RE2100, RT2047 prepared for DSC and RT2048

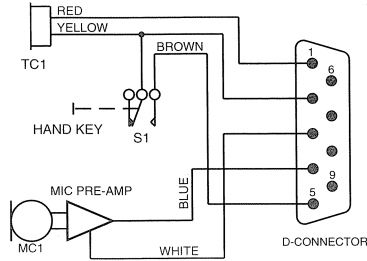

SHORTWAVE S130X

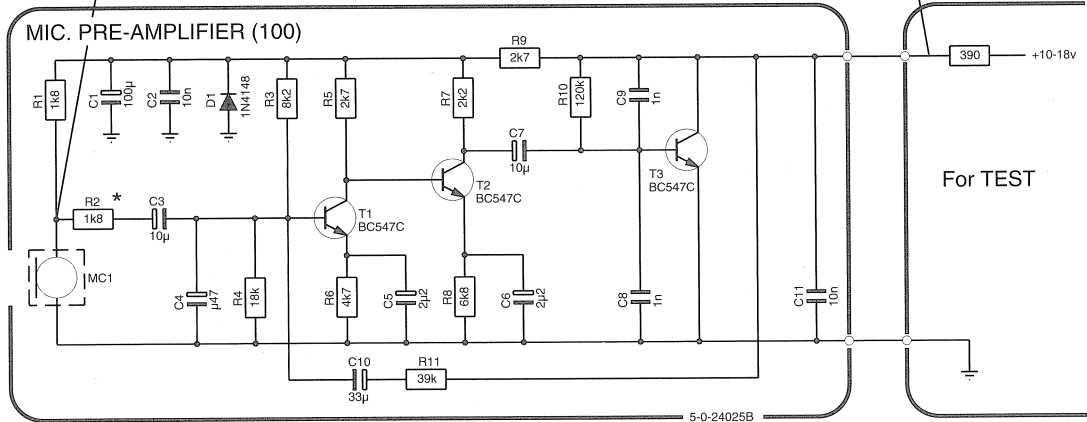
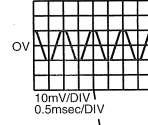
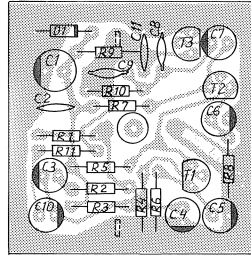
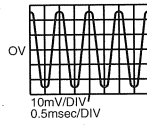
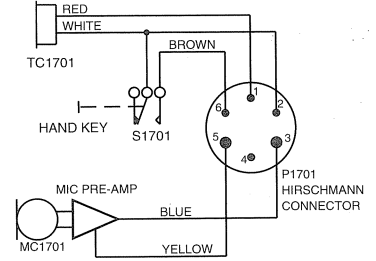

\* In orange marked microtelephone cartridge, R2 is changed from 1k8 to 5k6 ohm.

21777

RM2042 A  
4-0-27777

### MICROTELEPHONE WITH ELECTRET MIC. AMP.

ESPERA

5-0-24025D

600875

POSITION	DESCRIPTION		MANUFACTURER	TYPE	S.P. NUMBER
C1	CAPACITOR ELECTROLYTIC	100uF 20% 10VDC	ERO	EK1 00 BB 310 C MOE	14.607
C2	CAPACITOR CERAMIC	10nF -20/+80% CL2 50VDC	NKE	DT 350 758L F 103 Z 50V FLAT PACK	15.170
C3	CAPACITOR ELECTROLYTIC	10uF 20% 35VDC	ERO	EK1 00 AA 210 F MOE	14.512
C4	CAPACITOR ELECTROLYTIC	0.47uF 20% 50VDC	ERO	EK1 00 AA 047 H MOE	14.504
C5	CAPACITOR ELECTROLYTIC	2u2F 20% 50VDC	ERO	EK1 00 AA 122 H MOE	14.503
C6	CAPACITOR ELECTROLYTIC	2u2F 20% 50VDC	ERO	EK1 00 AA 122 H MOE	14.503
C7	CAPACITOR ELECTROLYTIC	10uF 20% 35VDC	ERO	EK1 00 AA 210 F MOE	14.512
C8	CAPACITOR CERAMIC	1nF 10% 100V	*PHILIPS	2222 630 19102	16.149
C9	CAPACITOR CERAMIC	1nF 10% 100V	*PHILIPS	2222 630 19102	16.149
C10	CAPACITOR ELECTROLYTIC	33uF 20% 16VDC	ERO	EK1 00 AA 233 D MOE	14.518
C11	CAPACITOR CERAMIC	10nF -20/+80% CL2 50VDC	NKE	DT 350 758L F 103 Z 50V FLAT PACK	15.170
D1	DIODE	1N4148 HIGH SPEED	PHILIPS	1N4148-143	25.131
MC1	MICROPHONE ELECTRET	ø9.7 x 6.7mm	PANASONIC	WM-0344BY	46.012
R1	RESISTOR MF	1k8 OHM 5% 0.33W	PHILIPS	2322 180 73182	02.478
R2	RESISTOR MF	1k8 OHM 5% 0.33W	PHILIPS	2322 180 73182	02.478
R3	RESISTOR MF	8k2 OHM 5% 0.33W	PHILIPS	2322 180 73822	02.494
R4	RESISTOR MF	18k OHM 5% 0.33W	PHILIPS	2322 180 73183	02.502
R5	RESISTOR MF	2k7 OHM 5% 0.33W	PHILIPS	2322 180 73272	02.482
R6	RESISTOR MF	4k7 OHM 5% 0.33W	PHILIPS	2322 180 73472	02.488
R7	RESISTOR MF	2k2 OHM 5% 0.33W	PHILIPS	2322 180 73222	02.480
R8	RESISTOR MF	6k8 OHM 5% 0.33W	PHILIPS	2322 180 73682	02.492
R9	RESISTOR MF	2k7 OHM 5% 0.33W	PHILIPS	2322 180 73272	02.482
R10	RESISTOR MF	120k OHM 5% 0.33W	PHILIPS	2322 180 73124	02.522
R11	RESISTOR MF	39k OHM 5% 0.33W	PHILIPS	2322 180 73393	02.510
S1	MICROSWITCH	E62-10H PDT	CHERRY	E62-10H PDT	44.025
T1	TRANSISTOR AF	NPN BC547C TO-92	PHILIPS	BC547C	28.068
T2	TRANSISTOR AF	NPN BC547C TO-92	PHILIPS	BC547C	28.068
T3	TRANSISTOR AF	NPN BC547C TO-92	PHILIPS	BC547C	28.068
TC1	TELEPHONE CARTRIDGE	200 OHMS	S.E.K. (KIRK)	T802 0113 2715	46.010



6.1. SPECIAL INSTALLATION WITH 2 MICROTELEPHONES:  
H2086 FOR SCRAMBLER CRY2001, RE2100, RT2048  
AND RT2047 PREPARED FOR DSC.  
H2087 FOR VHF RT2047 AND SSB T2031.

MICROTELEPHONE ONE WITH PREFERENCE

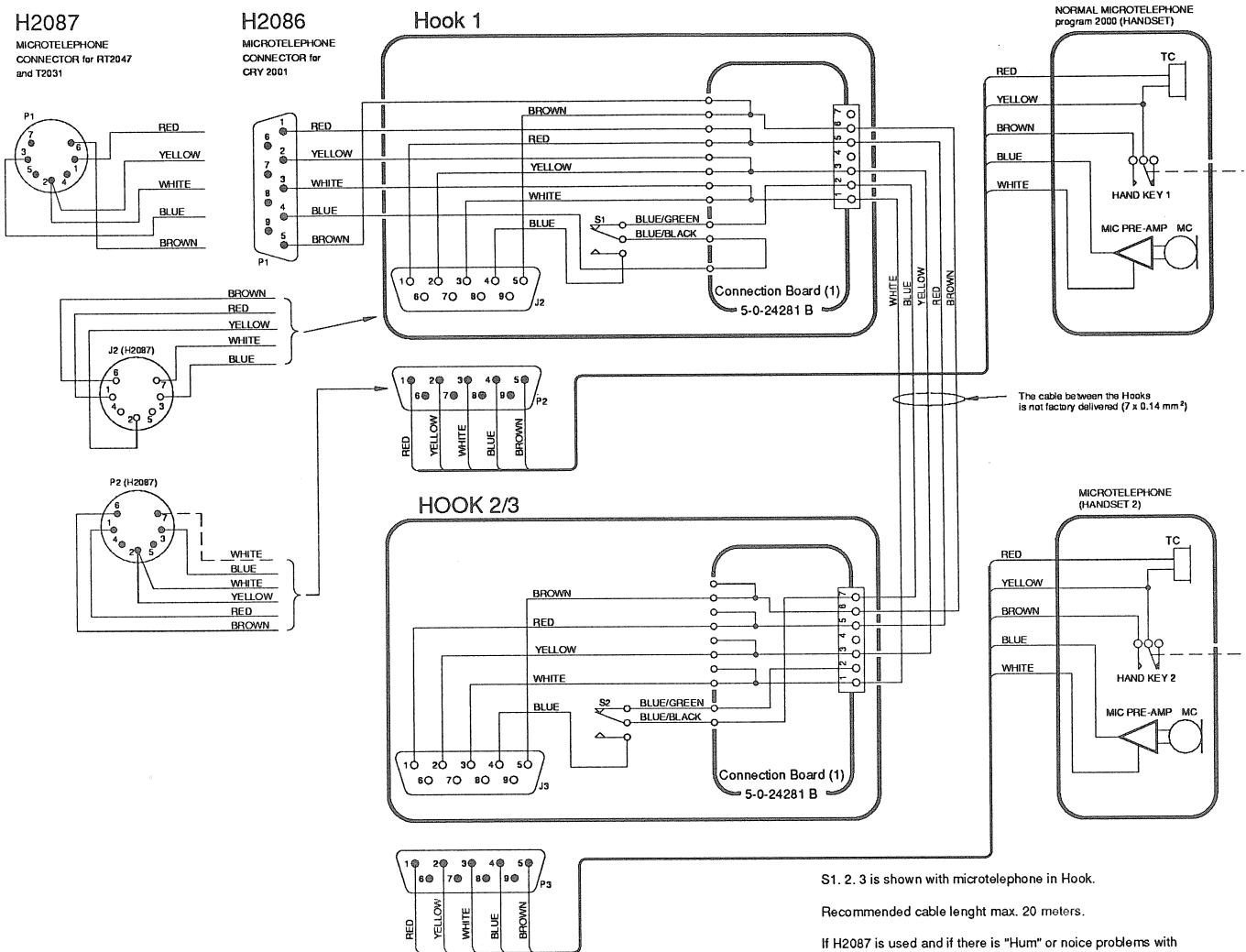

RM2042  
4-0-27778

6.2. SPECIAL INSTALLATION WITH 3 MICROTELEPHONES:  
H2088 FOR SCRAMBLER CRY2001, RE2100, RT2048  
AND RT2047 PREPARED FOR DSC.  
H2089 FOR VHF RT2047 AND SSB T2031.

MICROTELEPHONE ONE WITH PREFERENCE

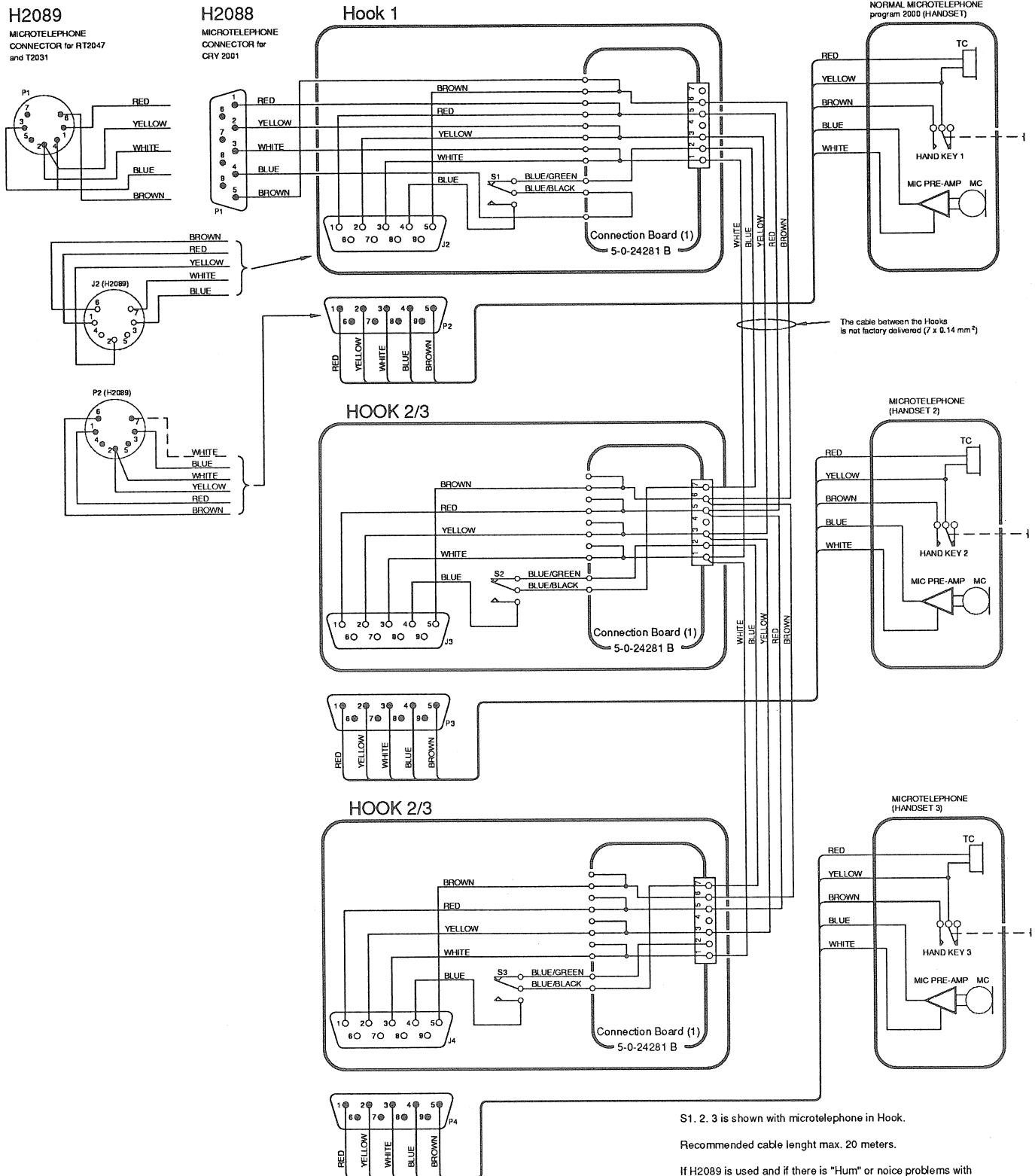

RM2042  
4-0-27779

### 6.3. MECHANICAL DIMENSIONS FOR HANDSET

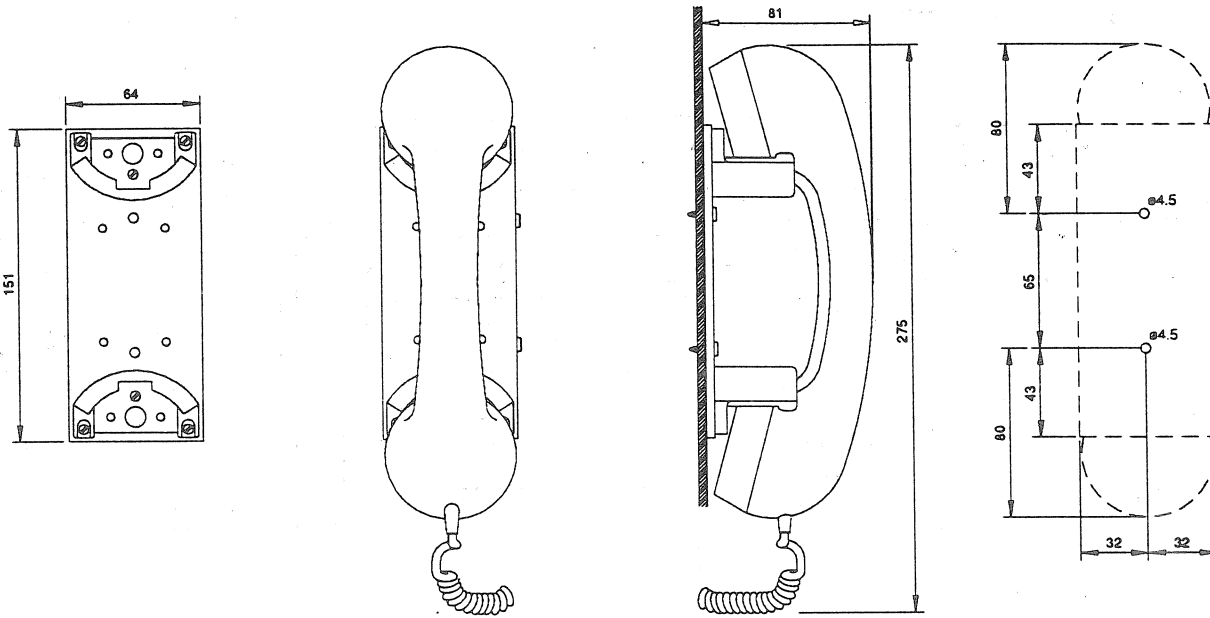

### MECHANICAL DIMENSIONS FOR HANDSET HOLDER WITH MICROSWITCH

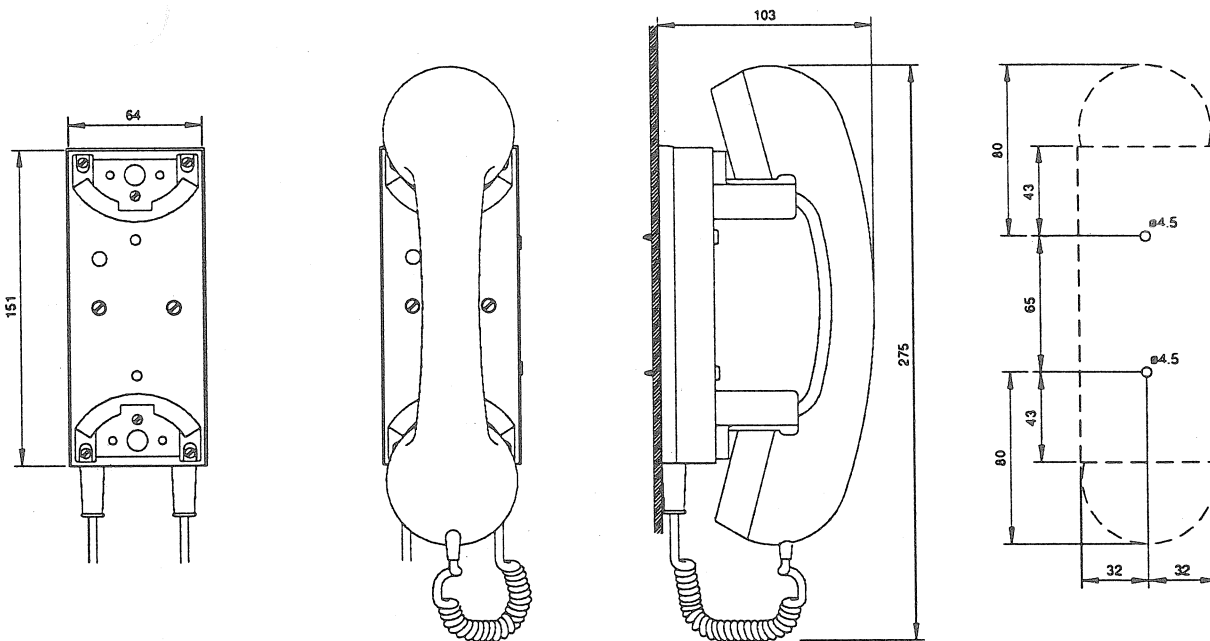

## CONTENTS

### 7. PARTS LIST



7 PARTS LISTS

VHF DSC RM2042		SAILOR GREEN	S.P. RADIO A/S VHF DSC RM2042		802042
POSITION	DESCRIPTION		MANUFACTOR	TYPE	S.P.NUMBER
VARIOUS	MINI 1/4 BOX CABINET	SAILOR GREEN		225435 GRØN RILSAN ALUMINIUM	22543500
VARIOUS	POWER CABLE WITH PLUG		ESPERA	503758 POWERKABEL	503758
VARIOUS	INTERCONNECTION CABLE		S.P.RADIO	3-0-26947B	526947
VARIOUS	AERIAL PLUG	PL259	* RODAN	PL259/LODDE/BAKELIT INDL.	78.502
VARIOUS	OPERATION MANUAL	RM2042 ENGLISH	HESTBECH & CO.		B2042GB
VARIOUS	SERVICE AND SALES AGENTS	ADRESSES WORLD WIDE	S.P.RADIO A/S		F1000GB
VARIOUS	MANUAL RM2042 ENGLISH		S.P.RADIO A/S		M2042GB

BASE UNIT RM2042 STD.			S.P. RADIO A/S		702042
POSITION	DESCRIPTION		MANUFACTOR	TYPE	S.P.NUMBER
VARIOUS	BUS-INTERRUPT OPTION (6)	RM2042	ESPERA	5-0-26945A	626945
-1	INTERFACE MODULE 1	RM2042	ESPERA	5-0-26941E / 4-0-26941J	626941
-2	MICROPROCESSOR (MODULE 2)	RM2042	ESPERA	5-0-26942G / 4-0-26942G	626942
-3	RECEIVER (MODULE 3) RM204	RM2042	ESPERA	5-0-26943D / 4-0-26943I	626943
-4	DISPLAY PRINT	RM2042 / RM2150 / RM2151	ESPERA	5-0-26944E / 4-0-24944F	626944
-6	KEYBOARD MODULE 6	RE2100/C2140	ESPERA	5-0-25636E	625636
U1-1	POS. VOLTAGE REG. FIXED	5V/1A 7805CT/LM340T-5.0	MOTOROLA	MC7805CT	31.250
U3-2	PROGRAMMED PROM U3-2	RM2042 (C1109,"ODD")	S.P. RADIO A/S	0-0-28221 / C1109-4200	728221
U5-2	PROGRAMMED PROM U5-2	RM2042 (C1110,"EVEN")	S.P. RADIO A/S	0-0-28222 / C1110-FC65	728222

INTERFACE MODULE 1		RM2042	ESPERA	5-0-26941E / 4-0-26941J	626941
POSITION	DESCRIPTION		MANUFACTOR	TYPE	S.P.NUMBER
VARIOUS	FUSECLIP	FOR 20x5mm FUSELINK	# LITTEL FUSE	111501	78.396
C1-1	CAPACITOR CERAM. SMD 0805	100nF 10% X7R 25VDC	MURATA	GRM40 X7R 104 K 25 PT REEL a 3000 STK	328.348
C2-1	CAPACITOR ELECTROLYTIC SM	10uF 20% 16VDC	ERO	ECV 00 AC 210 D 00 REEL a 2000 STK	333.079
C3-1	CAPACITOR ELECTROLYTIC	1000uF 20% 35VDC	SAMHWA ELEC.	SV-1000uF-35WV	14.655
C4-1	CAPACITOR ELECTROLYTIC	1000uF 20% 35VDC	SAMHWA ELEC.	SV-1000uF-35WV	14.655
C5-1	CAPACITOR TANTALUM 3528	2u2F 20% 16VDC	ERO	CB 225020 M E17 REEL a 2000 STK	334.028
C6-1	CAPACITOR CERAM. SMD 0805	100nF 10% X7R 25VDC	MURATA	GRM40 X7R 104 K 25 PT REEL a 3000 STK	328.348
C7-1	CAPACITOR CERAM. SMD 0805	100nF 10% X7R 25VDC	MURATA	GRM40 X7R 104 K 25 PT REEL a 3000 STK	328.348
C8-1	CAPACITOR CERAM. SMD 0805	47nF 10% X7R 50VDC	MURATA	GRM40 X7R 473 K 50 PT REEL a 3000 STK	328.344
C9-1	CAPACITOR CERAM. SMD 0805	1n0F 10% X7R 50VDC	MURATA	GRM40 X7R 102 K 50 PT REEL a 4000 STK	328.324
C10-1	CAPACITOR CERAM. SMD 0805	100nF 10% X7R 25VDC	MURATA	GRM40 X7R 104 K 25 PT REEL a 3000 STK	328.348
C11-1	CAPACITOR ELECTROLYTIC SM	10uF 20% 16VDC	ERO	ECV 00 AC 210 D 00 REEL a 2000 STK	333.079
C12-1	CAPACITOR CERAM. SMD 0805	100nF 10% X7R 25VDC	MURATA	GRM40 X7R 104 K 25 PT REEL a 3000 STK	328.348
C13-1	CAPACITOR CERAM. SMD 0805	100nF 10% X7R 25VDC	MURATA	GRM40 X7R 104 K 25 PT REEL a 3000 STK	328.348
C14-1	CAPACITOR CERAM. SMD 0805	10nF 10% X7R 50VDC	MURATA	GRM40 X7R 103 K 50 PT REEL a 4000 STK	328.336
C15-1	CAPACITOR ELECTROLYTIC SM	3u3F 20% 50VDC	ERO	ECV 00 AC 133 H 00 REEL a 2000 STK	333.073
LC16-1	CAPACITOR MKT	1u5F 10% 50VDC	ERO	MKT 1826 515/05 5-G	11.191
C17-1	CAPACITOR CERAM. SMD 0805	100nF 10% X7R 25VDC	MURATA	GRM40 X7R 104 K 25 PT REEL a 3000 STK	328.348
C18-1	CAPACITOR CERAM. SMD 0805	100nF 10% X7R 25VDC	MURATA	GRM40 X7R 104 K 25 PT REEL a 3000 STK	328.348

92/47

## 7 PARTS LIST

RM2042

POSITION	DESCRIPTION		MANUFACTOR	TYPE	S.P.NUMBER
C22-1	CAPACITOR CERAM. SMD 0805	1n0F 10% X7R 50VDC	MURATA	REEL a 3000 STK GRM40 X7R 102 K 50 PT	328.324
C23-1	CAPACITOR CERAM. SMD 0805	100nF 10% X7R 25VDC	MURATA	REEL a 4000 STK GRM40 X7R 104 K 25 PT	328.348
C24-1	CAPACITOR CERAM. SMD 0805	100nF 10% X7R 25VDC	MURATA	REEL a 3000 STK GRM40 X7R 104 K 25 PT	328.348
C25-1	CAPACITOR CERAM. SMD 0805	100nF 10% X7R 25VDC	MURATA	REEL a 3000 STK GRM40 X7R 104 K 25 PT	328.348
C26-1	CAPACITOR CERAM. SMD 0805	100nF 10% X7R 25VDC	MURATA	REEL a 3000 STK GRM40 X7R 104 K 25 PT	328.348
C27-1	CAPACITOR CERAM. SMD 1206	1u0F -20/80% Y5V 16VDC	MURATA	REEL a 3000 STK GRM42-6 Y5V 105 Z 16 PT	328.806
C28-1	CAPACITOR CERAM. SMD 0805	1n0F 10% X7R 50VDC	MURATA	REEL a 3000 STK GRM40 X7R 102 K 50 PT	328.324
C29-1	CAPACITOR CERAM. SMD 0805	100nF 10% X7R 25VDC	MURATA	REEL a 4000 STK GRM40 X7R 104 K 25 PT	328.348
C30-1	CAPACITOR ELECTROLYTIC SM	10uF 20% 16VDC	ERO	REEL a 3000 STK ECV 00 AC 210 D 00	333.079
C31-1	CAPACITOR ELECTROLYTIC SM	10uF 20% 16VDC	ERO	REEL a 2000 STK ECV 00 AC 210 D 00	333.079
C32-1	CAPACITOR ELECTROLYTIC SM	10uF 20% 16VDC	ERO	REEL a 2000 STK ECV 00 AC 210 D 00	333.079
C33-1	CAPACITOR ELECTROLYTIC SM	10uF 20% 16VDC	ERO	REEL a 2000 STK ECV 00 AC 210 D 00	333.079
C34-1	CAPACITOR ELECTROLYTIC SM	10uF 20% 16VDC	ERO	REEL a 2000 STK ECV 00 AC 210 D 00	333.079
C35-1	CAPACITOR CERAM. SMD 0805	100nF 10% X7R 25VDC	MURATA	REEL a 2000 STK GRM40 X7R 104 K 25 PT	328.348
C36-1	CAPACITOR CERAM. SMD 0805	1n0F 10% X7R 50VDC	MURATA	REEL a 3000 STK GRM40 X7R 102 K 50 PT	328.324
C37-1	CAPACITOR CERAM. SMD 0805	2n2F 10% X7R 50VDC	MURATA	REEL a 4000 STK GRM40 X7R 222 K 50 PT	328.328
C38-1	CAPACITOR CERAM. SMD 0805	2n2F 10% X7R 50VDC	MURATA	REEL a 4000 STK GRM40 X7R 222 K 50 PT	328.328
C39-1	CAPACITOR CERAM. SMD 0805	2n2F 10% X7R 50VDC	MURATA	REEL a 4000 STK GRM40 X7R 222 K 50 PT	328.328
C40-1	CAPACITOR CERAM. SMD 0805	2n2F 10% X7R 50VDC	MURATA	REEL a 4000 STK GRM40 X7R 222 K 50 PT	328.328
C41-1	CAPACITOR CERAM. SMD 0805	2n2F 10% X7R 50VDC	MURATA	REEL a 4000 STK GRM40 X7R 222 K 50 PT	328.328
C42-1	CAPACITOR CERAM. SMD 0805	2n2F 10% X7R 50VDC	MURATA	REEL a 4000 STK GRM40 X7R 222 K 50 PT	328.328
C43-1	CAPACITOR CERAM. SMD 0805	2n2F 10% X7R 50VDC	MURATA	REEL a 4000 STK GRM40 X7R 222 K 50 PT	328.328
C44-1	CAPACITOR CERAM. SMD 0805	2n2F 10% X7R 50VDC	MURATA	REEL a 4000 STK GRM40 X7R 222 K 50 PT	328.328
C45-1	CAPACITOR CERAM. SMD 0805	100nF 10% X7R 25VDC	MURATA	REEL a 4000 STK GRM40 X7R 104 K 25 PT	328.348
C46-1	CAPACITOR EMI	KOND.EMI 2n2 100V	MURATA	REEL a 3000 STK NFM41R10C222T1	335.422
C47-1	CAPACITOR EMI	KOND.EMI 2n2 100V	MURATA	NFM41R10C222T1	335.422
C48-1	CAPACITOR EMI	KOND.EMI 2n2 100V	MURATA	NFM41R10C222T1	335.422
C49-1	CAPACITOR EMI	KOND.EMI 2n2 100V	MURATA	NFM41R10C222T1	335.422
C50-1	CAPACITOR EMI	KOND.EMI 2n2 100V	MURATA	NFM41R10C222T1	335.422
C51-1	CAPACITOR EMI	KOND.EMI 2n2 100V	MURATA	NFM41R10C222T1	335.422
C52-1	CAPACITOR TANTALUM 3528	2u2F 20% 16VDC	ERO	REEL a 2000 STK CB 225020 M E17	334.028
C53-1	CAPACITOR TANTALUM 3528	2u2F 20% 16VDC	ERO	REEL a 2000 STK CB 225020 M E17	334.028
C54-1	CAPACITOR CERAM. SMD 0805	10nF 10% X7R 50VDC	MURATA	REEL a 3000 STK GRM40 X7R 103 K 50 PT	328.336
C55-1	CAPACITOR CERAM. SMD 0805	100nF 10% X7R 25VDC	MURATA	REEL a 4000 STK GRM40 X7R 104 K 25 PT	328.348
C56-1	CAPACITOR EMI	KOND.EMI 2n2 100V	MURATA	REEL a 3000 STK NFM41R10C222T1	335.422
C57-1	CAPACITOR EMI	KOND.EMI 2n2 100V	MURATA	NFM41R10C222T1	335.422
C58-1	CAPACITOR CERAM. SMD 1206	1u0F -20/80% Y5V 16VDC	MURATA	REEL a 3000 STK GRM42-6 Y5V 105 Z 16 PT	328.806
C59-1	CAPACITOR CERAM. SMD 0805	100nF 10% X7R 25VDC	MURATA	REEL a 3000 STK GRM40 X7R 104 K 25 PT	328.348
C60-1	CAPACITOR CERAM. SMD 0805	10nF 10% X7R 50VDC	MURATA	REEL a 3000 STK GRM40 X7R 103 K 50 PT	328.336

92/47

## 7 PARTS LIST

RM2042

POSITION	DESCRIPTION		MANUFACTOR	TYPE	S.P.NUMBER
C62-1	CAPACITOR CERAM. SMD 1206	100nF 10% X7R 50VDC	MURATA	REEL a 4000 STK GRM42-6 X7R 104 K 50 PT	328.648
C63-1	CAPACITOR TANTALUM 3528	2u2F 20% 16VDC	ERO	REEL a 4000 STK CB 225020 M E17	334.028
C64-1	CAPACITOR ELECTROLYTIC SM	3u3F 20% 50VDC	ERO	REEL a 2000 STK ECV 00 AC 133 H 00	333.073
C65-1	CAPACITOR TANTALUM 3528	2u2F 20% 16VDC	ERO	REEL a 2000 STK CB 225020 M E17 REEL a 2000 STK	334.028
D1-1	DIODE RECTIFIER	1N4002 100V/1A	THOMSON	1N4002 (03/04/05/06/07)	25.100
D2-1	DIODE	1.5SMC20A	MOTOROLA	1.5SMC20A	341.430
D3-1	DIODE	BAS32L	PHILIPS	BAS32L	340.032
D4-1	DIODE	BAS32L	PHILIPS	BAS32L	340.032
D5-1					340.317
D6-1	DIODE	BAS32L	PHILIPS	BAS32L	340.032
D7-1	DIODE	BAS32L	PHILIPS	BAS32L	340.032
F1-1	FUSE	2AF 5x20mm	ELU	179 020 2AF	45.556
FP1-1	EMI FERRITE BEAD	4.5x1.6x1.6mm 0.5A	MURATA	BLM 41 A01 PT/Ø180 REEL REEL a 2500 STK	370.031
FP2-1	EMI FERRITE BEAD	4.5x1.6x1.6mm 0.5A	MURATA	BLM 41 A01 PT/Ø180 REEL REEL a 2500 STK	370.031
J1-1	SOCKET SUB D 9 POLES	PCB VERSION 2x 4-40 NUT	NS TECH	DMS-9SBTS-"E"	78.164
J2-1	SOCKET BNC	PCB VERSION	ROSENBERGER	51K102-400 A4	78.444
J3-1	SOCKET SUB D 9 POLES	PCB VERSION 2x 4-40 NUT	NS TECH	DMS-9SBTS-"E"	78.164
J4-1	SOCKET SUB D	25 POLES PCB VERSION	EDA INC.	8TO-025SS-244T	78.166
L1-1	COIL RF	8u2	SIEMENS	B82412-A1822-M	337.135
L2-1	COIL RF	8u2	SIEMENS	B82412-A1822-M	337.135
OC1-1	OPTO COUPLER OC207		MOTOROLA	MOC207	353.057
P1-1	PLUG	1/10" DIL SQ.PINS 6 POLES	AMP	826656-3	78.340
P2-1	PLUG SUB D	9 POLES PCB VERSION	EDA INC.	8TO-009PS-241T	78.163
P3-1	PLUG	6 POLES	HIRSCHMANN	973 887-100 UDEN FRÆSNING I BEN	78.315
P4-1	PLUG 2 POLES	VERTICAL PCB VERSION	JST	B2B-ZR	78.448
P5-1	SMD PLUG (MALE)	16 POLES	AMP	4-175643-6	375.005
P6-1	SMD PLUG (MALE)	16 POLES	AMP	4-175643-6	375.005
P7-1	SMD PLUG (MALE)	16 POLES	AMP	4-175643-6	375.005
P8-1	SMD PLUG (MALE)	16 POLES	AMP	4-175643-6	375.005
P9-1	SMD PLUG (MALE)	16 POLES	AMP	4-175643-6	375.005
Q2-1	TRANSISTOR LF	BC848B NPN SMD	PHILIPS	BC848B	345.048
Q3-1	TRANSISTOR LF	BC848B NPN SMD	PHILIPS	BC848B	345.048
Q4-1	TRANSISTOR LF	BCP55-16 NPN SMD	SIEMENS	BCP55-16	345.355
Q5-1	TRANSISTOR LF	BC848B NPN SMD	PHILIPS	BC848B	345.048
Q6-1	TRANSISTOR NPN	BCP52-16 1.5W	PHILIPS	Q62702-C2113	346.352
Q7-1	TRANSISTOR LF	BC848B NPN SMD	PHILIPS	BC848B	345.048
Q8-1	TRANSISTOR LF	BC848B NPN SMD	PHILIPS	BC848B	345.048
Q9-1	TRANSISTOR LF	BC858B NPN SMD	PHILIPS	BC858B	345.058
R2-1	RESISTOR SMD 0805	100k OHM 5% 0.1W	ROHM	MCR 10 JZO J 104 E REEL a 5000 STK	302.072
R3-1	RESISTOR SMD 0805	2k2 OHM 5% 0.1W	ROHM	MCR 10 JZO J 222 E REEL a 5000 STK	302.052
R4-1	RESISTOR SMD 0805	100k OHM 5% 0.1W	ROHM	MCR 10 JZO J 104 E REEL a 5000 STK	302.072
R5-1	RESISTOR SMD 0805	100 OHM 5% 0.1W	ROHM	MCR 10 JZO J 101 E REEL a 5000 STK	302.036
R6-1	RESISTOR SMD 0805	100k OHM 5% 0.1W	ROHM	MCR 10 JZO J 104 E REEL a 5000 STK	302.072
R7-1	RESISTOR SMD 0805	47k OHM 5% 0.1W	ROHM	MCR 10 JZO J 473 E REEL a 5000 STK	302.068
R8-1	RESISTOR SMD 0805	10k OHM 5% 0.1W	ROHM	MCR 10 JZO J 103 E REEL a 5000 STK	302.060
R9-1	RESISTOR SMD 0805	27k OHM 5% 0.1W	ROHM	MCR 10 JZO J 273 E REEL a 5000 STK	302.065
R10-1	RESISTOR SMD 0805	47k OHM 5% 0.1W	ROHM	MCR 10 JZO J 473 E REEL a 5000 STK	302.068
R11-1	RESISTOR SMD 0805	27k OHM 5% 0.1W	ROHM	MCR 10 JZO J 273 E REEL a 5000 STK	302.065
R12-1	RESISTOR SMD 0805	10k OHM 5% 0.1W	ROHM	MCR 10 JZO J 103 E REEL a 5000 STK	302.060
R13-1	RESISTOR SMD 0805	220k OHM 5% 0.1W	ROHM	MCR 10 JZO J 224 E REEL a 5000 STK	302.076
R14-1	RESISTOR SMD 0805	220k OHM 5% 0.1W	ROHM	MCR 10 JZO J 224 E	302.076

92/47



## 7 PARTS LIST

RM2042

POSITION	DESCRIPTION		MANUFACTOR	TYPE	S.P.NUMBER
R14-1	RESISTOR SMD 0805	220k OHM 5% 0.1W	ROHM	MCR 10 JZO J 224 E REEL a 5000 STK	302.076
R15-1	RESISTOR SMD 0805	220k OHM 5% 0.1W	ROHM	MCR 10 JZO J 224 E REEL a 5000 STK	302.076
R16-1	RESISTOR SMD 0805	2k2 OHM 5% 0.1W	ROHM	MCR 10 JZO J 222 E REEL a 5000 STK	302.052
R17-1	PRESET SEALED	100k OHM 20% 1/4W	BOURNS	3314J-1-104-E(G) REEL a 750(3000) STK	310.412
R18-1	RESISTOR SMD 0805	47k OHM 5% 0.1W	ROHM	MCR 10 JZO J 473 E REEL a 5000 STK	302.068
R19-1	RESISTOR SMD 0805	2k2 OHM 5% 0.1W	ROHM	MCR 10 JZO J 222 E REEL a 5000 STK	302.052
R20-1	RESISTOR SMD 0805	27 OHM 5% 0.1W	ROHM	MCR 10 JZO J 27R E REEL a 5000 STK	302.029
R21-1	RESISTOR SMD 0805	1k0 OHM 5% 0.1W	ROHM	MCR 10 JZO J 102 E REEL a 5000 STK	302.048
R22-1	PRESET SEALED	100k OHM 20% 1/4W	BOURNS	3314J-1-104-E(G) REEL a 750(3000) STK	310.412
R23-1	RESISTOR SMD 0805	2k7 OHM 5% 0.1W	ROHM	MCR 10 JZO J 272 E REEL a 5000 STK	302.053
R24-1	RESISTOR SMD 0805	100k OHM 5% 0.1W	ROHM	MCR 10 JZO J 104 E REEL a 5000 STK	302.072
R25-1	RESISTOR SMD 0805	100k OHM 5% 0.1W	ROHM	MCR 10 JZO J 104 E REEL a 5000 STK	302.072
R26-1	RESISTOR SMD 0805	1k0 OHM 5% 0.1W	ROHM	MCR 10 JZO J 102 E REEL a 5000 STK	302.048
R27-1	RESISTOR SMD 0805	27 OHM 5% 0.1W	ROHM	MCR 10 JZO J 27R E REEL a 5000 STK	302.029
R28-1	RESISTOR SMD 0805	205k OHM 1% 50mW	PHILIPS	2322 734 2/62054 REEL a 5000 STK	302.600
R29-1	RESISTOR SMD 0805	2k2 OHM 5% 0.1W	ROHM	MCR 10 JZO J 222 E REEL a 5000 STK	302.052
R30-1	RESISTOR SMD 0805	10k OHM 5% 0.1W	ROHM	MCR 10 JZO J 103 E REEL a 5000 STK	302.060
R38-1	RESISTOR SMD 0805	100k OHM 5% 0.1W	ROHM	MCR 10 JZO J 104 E REEL a 5000 STK	302.072
R39-1	RESISTOR SMD 0805	10k OHM 5% 0.1W	ROHM	MCR 10 JZO J 103 E REEL a 5000 STK	302.060
R40-1	RESISTOR SMD 0805	120k OHM 5% 0.1W	ROHM	MCR 10 JZO J 124 E REEL a 5000 STK	302.073
R41-1	RESISTOR SMD 0805	330 OHM 5% 0.1W	ROHM	MCR 10 JZO J 331 E REEL a 5000 STK	302.042
R42-1	RESISTOR SMD 0805	330 OHM 5% 0.1W	ROHM	MCR 10 JZO J 331 E REEL a 5000 STK	302.042
R43-1	RESISTOR SMD 0805	2k7 OHM 5% 0.1W	ROHM	MCR 10 JZO J 272 E REEL a 5000 STK	302.053
R44-1	RESISTOR SMD 0805	100k OHM 5% 0.1W	ROHM	MCR 10 JZO J 104 E REEL a 5000 STK	302.072
R45-1	RESISTOR SMD 0805	3k9 OHM 5% 0.1W	ROHM	MCR 10 JZO J 392 E REEL a 5000 STK	302.055
R46-1	RESISTOR SMD 0805	47 OHM 5% 0.1W	ROHM	MCR 10 JZO J 47R E REEL a 5000 STK	302.032
R47-1	RESISTOR SMD 0805	10k OHM 5% 0.1W	ROHM	MCR 10 JZO J 103 E REEL a 5000 STK	302.060
R48-1	RESISTOR SMD 0805	10k OHM 5% 0.1W	ROHM	MCR 10 JZO J 103 E REEL a 5000 STK	302.060
R49-1	RESISTOR SMD 0805	10k OHM 5% 0.1W	ROHM	MCR 10 JZO J 103 E REEL a 5000 STK	302.060
R50-1	RESISTOR SMD 0805	10k OHM 5% 0.1W	ROHM	MCR 10 JZO J 103 E REEL a 5000 STK	302.060
R51-1	RESISTOR SMD 0805	1k0 OHM 5% 0.1W	ROHM	MCR 10 JZO J 102 E REEL a 5000 STK	302.048
R52-1	RESISTOR SMD 0805	4k7 OHM 5% 0.1W	ROHM	MCR 10 JZO J 472 E REEL a 5000 STK	302.056
R53-1	RESISTOR SMD 0805	4k7 OHM 5% 0.1W	ROHM	MCR 10 JZO J 472 E REEL a 5000 STK	302.056
R54-1	RESISTOR SMD 0805	4k7 OHM 5% 0.1W	ROHM	MCR 10 JZO J 472 E REEL a 5000 STK	302.056
R55-1	RESISTOR SMD 0805	4k7 OHM 5% 0.1W	ROHM	MCR 10 JZO J 472 E REEL a 5000 STK	302.056
R56-1	RESISTOR SMD 0805	4k7 OHM 5% 0.1W	ROHM	MCR 10 JZO J 472 E	302.056

9247

## 7 PARTS LIST

RM2042

POSITION	DESCRIPTION		MANUFACTOR	TYPE	S.P.NUMBER
R57-1	RESISTOR SMD 0805	4k7 OHM 5% 0.1W	ROHM	REEL a 5000 STK MCR 10 JZO J 472 E	302.056
R58-1	RESISTOR SMD 0805	100k OHM 5% 0.1W	ROHM	REEL a 5000 STK MCR 10 JZO J 104 E	302.072
R59-1	RESISTOR SMD 0805	100 OHM 5% 0.1W	ROHM	REEL a 5000 STK MCR 10 JZO J 101 E	302.036
R60-1	RESISTOR SMD 0805	47k OHM 5% 0.1W	ROHM	REEL a 5000 STK MCR 10 JZO J 473 E	302.068
R61-1	RESISTOR SMD 0805	47k OHM 5% 0.1W	ROHM	REEL a 5000 STK MCR 10 JZO J 473 E	302.068
R62-1	RESISTOR SMD 0805	1k0 OHM 5% 0.1W	ROHM	REEL a 5000 STK MCR 10 JZO J 102 E	302.048
R63-1	RESISTOR SMD 0805	10k OHM 5% 0.1W	ROHM	REEL a 5000 STK MCR 10 JZO J 103 E	302.060
R64-1	RESISTOR SMD 0805	3k9 OHM 5% 0.1W	ROHM	REEL a 5000 STK MCR 10 JZO J 392 E	302.055
R65-1	RESISTOR SMD 0805	100k OHM 5% 0.1W	ROHM	REEL a 5000 STK MCR 10 JZO J 104 E	302.072
R66-1	RESISTOR SMD 0805	390 OHM 5% 0.1W	ROHM	REEL a 5000 STK MCR 10 JZO J 391 E	302.043
R67-1	RESISTOR SMD 0805	100k OHM 5% 0.1W	ROHM	REEL a 5000 STK MCR 10 JZO J 104 E	302.072
R68-1	RESISTOR SMD 0805	100k OHM 5% 0.1W	ROHM	REEL a 5000 STK MCR 10 JZO J 104 E	302.072
R69-1	RESISTOR SMD 0805	10k OHM 5% 0.1W	ROHM	REEL a 5000 STK MCR 10 JZO J 103 E	302.060
R70-1	RESISTOR SMD 0805	10k OHM 5% 0.1W	ROHM	REEL a 5000 STK MCR 10 JZO J 103 E	302.060
R71-1	RESISTOR SMD 0805	10k OHM 5% 0.1W	ROHM	REEL a 5000 STK MCR 10 JZO J 103 E	302.060
R72-1	RESISTOR SMD 0805	10k OHM 5% 0.1W	ROHM	REEL a 5000 STK MCR 10 JZO J 103 E	302.060
R73-1	RESISTOR SMD 0805	10k OHM 5% 0.1W	ROHM	REEL a 5000 STK MCR 10 JZO J 103 E	302.060
R74-1	RESISTOR SMD 0805	1k0 OHM 5% 0.1W	ROHM	REEL a 5000 STK MCR 10 JZO J 102 E	302.048
R75-1	RESISTOR SMD 0805	100k OHM 1% 50mW	PHILIPS	REEL a 5000 STK 2322 734 2/61004	302.570
R76-1	RESISTOR SMD 0805	205k OHM 1% 50mW	PHILIPS	REEL a 5000 STK 2322 734 2/62054	302.600
R77-1	RESISTOR SMD 0805	100k OHM 1% 50mW	PHILIPS	REEL a 5000 STK 2322 734 2/61004	302.570
RE1-1	RELAY 12VDC	1ADC DPDT	NEC	EA2-12	21.074
S1-1	SWITCH CS-4-22YTA		COPAL*	CS-4-22YTA	373.102
S2-1	INTEGRATED CIRCUIT		COPAL*	CS-4-12YTA	373.100
TR1-1	TRAFO AF	1:1 600 OHMS	SCANELECTRIC	REEL a 500 STK 714.065.79.1 EI 19/6,7-6579	22.502
U1-1	POS. VOLTAGE REG. FIXED	5V/1A 7805CT/LM340T-5.0	MOTOROLA	MC7805CT	31.250
U2-1	INTEGRATED CIRCUIT	LM339	TEXAS	LM339D	350.540
U3-1	QUAD OP.AMP.	LM324	TEXAS	LM324D	350.530
U4-1	AF POWER AMPLIFIER	DIL 8 1W BTL.	PHILIPS	TDA7052	31.432
U5-1	VOLTAGE REGULATOR	5V/0.5A	MOTOTOLA	MC78M05CDT	350.125
U7-1	INTEGRATED CIRCUIT	82C51	OKI*	MSM82C51A-2JS	356.610
U8-1	INTEGRATED CIRCUIT	82C51	OKI*	MSM82C51A-2JS	356.610
U9-1	INTEGRATED CIRCUIT	82C51	OKI*	MSM82C51A-2JS	356.610
U10-1	INTEGRATED CIRCUIT	82C55	OKI	M82C55A-2V	356.616
U11-1	RS 232 DRIVER/RECEIVER	AD232/MAX232/DS14C232C	MAXIM	MAX 232 CWE (EWE)	356.605
U12-1	VOLTAGE REGULATOR	5V/0.1A	TEXAS	uA78L05ACD	350.100
W1-1	SHUNT CONNECTOR	FEMALE 2 POLES	SAMTEC	SNT-100-BK-G	78.325
W2-1	SHUNT CONNECTOR	FEMALE 2 POLES	SAMTEC	SNT-100-BK-G	78.325
W3-1	SHUNT CONNECTOR	FEMALE 2 POLES	SAMTEC	SNT-100-BK-G	78.325

92/47

POSITION	DESCRIPTION		MANUFACTOR	TYPE	S.P.NUMBER
<b>MICROPROCESSOR (MODULE 2)</b>		<b>RM2042</b>	<b>ESPERA</b>	<b>5-0-26942G / 4-0-26942G</b>	<b>626942</b>
POSITION	DESCRIPTION		MANUFACTOR	TYPE	S.P.NUMBER
VARIOUS	SOCKET PLOC	32 POLES LOW PROFILE	T.Z.T.	ZT-SMTP-S-32-T/O	376.803
B1-2	BATTERY LITHIUM	3V 0.36Ah Ø15x14mm	VARTA	6147 201 501 CR 1/4 AA SLF	47.004
C1-2	CAPACITOR CERAM. SMD 0805	100nF 10% X7R 25VDC	MURATA	GRM40 X7R 104 K 25 PT REEL a 3000 STK	328.348
C2-2	CAPACITOR CERAM. SMD 0805	100nF 10% X7R 25VDC	MURATA	GRM40 X7R 104 K 25 PT REEL a 3000 STK	328.348
C3-2	CAPACITOR CERAM. SMD 0805	100nF 10% X7R 25VDC	MURATA	GRM40 X7R 104 K 25 PT REEL a 3000 STK	328.348
C4-2	CAPACITOR CERAM. SMD 0805	100nF 10% X7R 25VDC	MURATA	GRM40 X7R 104 K 25 PT REEL a 3000 STK	328.348
C5-2	CAPACITOR CERAM. SMD 0805	100nF 10% X7R 25VDC	MURATA	GRM40 X7R 104 K 25 PT REEL a 3000 STK	328.348
C6-2	CAPACITOR CERAM. SMD 0805	100nF 10% X7R 25VDC	MURATA	GRM40 X7R 104 K 25 PT REEL a 3000 STK	328.348
C7-2	CAPACITOR CERAM. SMD 0805	100nF 10% X7R 25VDC	MURATA	GRM40 X7R 104 K 25 PT REEL a 3000 STK	328.348
C8-2	CAPACITOR CERAM. SMD 0805	100nF 10% X7R 25VDC	MURATA	GRM40 X7R 104 K 25 PT REEL a 3000 STK	328.348
C9-2	CAPACITOR CERAM. SMD 0805	100nF 10% X7R 25VDC	MURATA	GRM40 X7R 104 K 25 PT REEL a 3000 STK	328.348
C10-2	CAPACITOR CERAM. SMD 0805	100nF 10% X7R 25VDC	MURATA	GRM40 X7R 104 K 25 PT REEL a 3000 STK	328.348
C11-2	CAPACITOR CERAM. SMD 0805	100nF 10% X7R 25VDC	MURATA	GRM40 X7R 104 K 25 PT REEL a 3000 STK	328.348
C12-2	CAPACITOR CERAM. SMD 0805	100nF 10% X7R 25VDC	MURATA	GRM40 X7R 104 K 25 PT REEL a 3000 STK	328.348
C13-2	CAPACITOR CERAM. SMD 0805	100nF 10% X7R 25VDC	MURATA	GRM40 X7R 104 K 25 PT REEL a 3000 STK	328.348
C14-2	CAPACITOR TANTALUM 3216	1u5F 20% 16VDC	PANASONIC	ECSH 1C Y 155 R REEL a 2000 STK	334.007
C15-2	CAPACITOR CERAM. SMD 0805	100nF 10% X7R 25VDC	MURATA	GRM40 X7R 104 K 25 PT REEL a 3000 STK	328.348
C16-2	CAPACITOR CERAM. SMD 0805	100nF 10% X7R 25VDC	MURATA	GRM40 X7R 104 K 25 PT REEL a 3000 STK	328.348
C17-2	CAPACITOR CERAM. SMD 0805	33pF 5% NPO 50VDC	MURATA	GRM40 COG 330 J 50 PT REEL a 4000 STK	323.080
C18-2	CAPACITOR CERAM. SMD 0805	33pF 5% NPO 50VDC	MURATA	GRM40 COG 330 J 50 PT REEL a 4000 STK	323.080
C19-2	CAPACITOR CERAM. SMD 0805	33pF 5% NPO 50VDC	MURATA	GRM40 COG 330 J 50 PT REEL a 4000 STK	323.080
C20-2	CAPACITOR CERAM. SMD 0805	18pF 5% NPO 50VDC	MURATA	GRM40 COG 180 J 50 PT REEL a 4000 STK	323.077
C21-2	CAPACITOR CERAM. SMD 0805	100nF 10% X7R 25VDC	MURATA	GRM40 X7R 104 K 25 PT REEL a 3000 STK	328.348
C23-2	CAPACITOR CERAM. SMD 0805	100nF 10% X7R 25VDC	MURATA	GRM40 X7R 104 K 25 PT REEL a 3000 STK	328.348
C24-2	CAPACITOR CERAM. SMD 0805	100nF 10% X7R 25VDC	MURATA	GRM40 X7R 104 K 25 PT REEL a 3000 STK	328.348
C25-2	CAPACITOR CERAM. SMD 0805	100nF 10% X7R 25VDC	MURATA	GRM40 X7R 104 K 25 PT REEL a 3000 STK	328.348
C26-2	CAPACITOR CERAM. SMD 0805	100nF 10% X7R 25VDC	MURATA	GRM40 X7R 104 K 25 PT REEL a 3000 STK	328.348
C27-2	CAPACITOR CERAM. SMD 0805	100nF 10% X7R 25VDC	MURATA	GRM40 X7R 104 K 25 PT REEL a 3000 STK	328.348
C28-2	CAPACITOR CERAM. SMD 0805	100nF 10% X7R 25VDC	MURATA	GRM40 X7R 104 K 25 PT REEL a 3000 STK	328.348
C29-2	CAPACITOR CERAM. SMD 0805	100nF 10% X7R 25VDC	MURATA	GRM40 X7R 104 K 25 PT REEL a 3000 STK	328.348
C30-2	CAPACITOR CERAM. SMD 0805	100nF 10% X7R 25VDC	MURATA	GRM40 X7R 104 K 25 PT REEL a 3000 STK	328.348
C31-2	CAPACITOR CERAM. SMD 0805	100nF 10% X7R 25VDC	MURATA	GRM40 X7R 104 K 25 PT REEL a 3000 STK	328.348
C32-2	CAPACITOR CERAM. SMD 0805	100nF 10% X7R 25VDC	MURATA	GRM40 X7R 104 K 25 PT REEL a 3000 STK	328.348

92/47

## 7 PARTS LIST

RM2042

POSITION	DESCRIPTION		MANUFACTOR	TYPE	S.P.NUMBER
C33-2	CAPACITOR CERAM. SMD 0805	100nF 10% X7R 25VDC	MURATA	GRM40 X7R 104 K 25 PT REEL a 3000 STK	328.348
C34-2	CAPACITOR CERAM. SMD 0805	100nF 10% X7R 25VDC	MURATA	GRM40 X7R 104 K 25 PT REEL a 3000 STK	328.348
C35-2	CAPACITOR CERAM. SMD 0805	100nF 10% X7R 25VDC	MURATA	GRM40 X7R 104 K 25 PT REEL a 3000 STK	328.348
C36-2	CAPACITOR CERAM. SMD 0805	100nF 10% X7R 25VDC	MURATA	GRM40 X7R 104 K 25 PT REEL a 3000 STK	328.348
C37-2	CAPACITOR CERAM. SMD 0805	100nF 10% X7R 25VDC	MURATA	GRM40 X7R 104 K 25 PT REEL a 3000 STK	328.348
C38-2	CAPACITOR CERAM. SMD 0805	47pF 5% NPO 50VDC	MURATA	GRM40 COG 470 J 50 PT REEL a 4000 STK	323.082
C39-2	CAPACITOR TRIMMER SMD	4-25P	MURATA	TZB04Z250BA LEVERINGSFORM EJ FRIGIVET	335.024
C40-2	CAPACITOR CERAM. SMD 0805	100nF 10% X7R 25VDC	MURATA	GRM40 X7R 104 K 25 PT REEL a 3000 STK	328.348
C41-2	CAPACITOR ELECTROLYTIC SM	10uF 20% 16VDC	ERO	ECV 00 AC 210 D 00 REEL a 2000 STK	333.079
C42-2	CAPACITOR ELECTROLYTIC SM	10uF 20% 16VDC	ERO	ECV 00 AC 210 D 00 REEL a 2000 STK	333.079
C43-2	CAPACITOR CERAM. SMD 0805	100nF 10% X7R 25VDC	MURATA	GRM40 X7R 104 K 25 PT REEL a 3000 STK	328.348
C44-2	CAPACITOR CERAM. SMD 0805	100nF 10% X7R 25VDC	MURATA	GRM40 X7R 104 K 25 PT REEL a 3000 STK	328.348
C45-2	CAPACITOR TRIMMER SMD	4-25P	MURATA	TZB04Z250BA LEVERINGSFORM EJ FRIGIVET	335.024
C46-2	CAPACITOR ELECTROLYTIC SM	10uF 20% 16VDC	ERO	ECV 00 AC 210 D 00 REEL a 2000 STK	333.079
C47-2	CAPACITOR CERAM. SMD 0805	100nF 10% X7R 25VDC	MURATA	GRM40 X7R 104 K 25 PT REEL a 3000 STK	328.348
C48-2	CAPACITOR CERAM. SMD 0805	100nF 10% X7R 25VDC	MURATA	GRM40 X7R 104 K 25 PT REEL a 3000 STK	328.348
C49-2	CAPACITOR CERAM. SMD 0805	1n0F 10% X7R 50VDC	MURATA	GRM40 X7R 102 K 50 PT REEL a 4000 STK	328.324
C50-2	CAPACITOR CERAM. SMD 0805	1n0F 10% X7R 50VDC	MURATA	GRM40 X7R 102 K 50 PT REEL a 4000 STK	328.324
C51-2	CAPACITOR CERAM. SMD 0805	1n0F 10% X7R 50VDC	MURATA	GRM40 X7R 102 K 50 PT REEL a 4000 STK	328.324
C52-2	CAPACITOR CERAM. SMD 0805	1n0F 10% X7R 50VDC	MURATA	GRM40 X7R 102 K 50 PT REEL a 4000 STK	328.324
C53-2	CAPACITOR CERAM. SMD 0805	1n0F 10% X7R 50VDC	MURATA	GRM40 X7R 102 K 50 PT REEL a 4000 STK	328.324
C54-2	CAPACITOR CERAM. SMD 0805	1n0F 10% X7R 50VDC	MURATA	GRM40 X7R 102 K 50 PT REEL a 4000 STK	328.324
C55-2	CAPACITOR CERAM. SMD 0805	1n0F 10% X7R 50VDC	MURATA	GRM40 X7R 102 K 50 PT REEL a 4000 STK	328.324
D1-2	DIODE	BAS32L	PHILIPS	BAS32L	340.032
D2-2	DIODE	BAS32L	PHILIPS	BAS32L	340.032
FP1-2	EMI FERRITE BEAD	3.2x1.6x1.6mm 0.2A	MURATA	BLM 32 A06 PT/Ø180 REEL REEL a 3000 STK	370.021
FP2-2	EMI FERRITE BEAD	3.2x1.6x1.6mm 0.2A	MURATA	BLM 32 A06 PT/Ø180 REEL REEL a 3000 STK	370.021
FP3-2	EMI FERRITE BEAD	3.2x1.6x1.6mm 0.2A	MURATA	BLM 32 A06 PT/Ø180 REEL REEL a 3000 STK	370.021
FP4-2	EMI FERRITE BEAD	3.2x1.6x1.6mm 0.2A	MURATA	BLM 32 A06 PT/Ø180 REEL REEL a 3000 STK	370.021
FP5-2	EMI FERRITE BEAD	3.2x1.6x1.6mm 0.2A	MURATA	BLM 32 A06 PT/Ø180 REEL REEL a 3000 STK	370.021
FP6-2	EMI FERRITE BEAD	3.2x1.6x1.6mm 0.2A	MURATA	BLM 32 A06 PT/Ø180 REEL REEL a 3000 STK	370.021
FP7-2	EMI FERRITE BEAD	3.2x1.6x1.6mm 0.2A	MURATA	BLM 32 A06 PT/Ø180 REEL REEL a 3000 STK	370.021
FP8-2	EMI FERRITE BEAD	3.2x1.6x1.6mm 0.2A	MURATA	BLM 32 A06 PT/Ø180 REEL REEL a 3000 STK	370.021
FP9-2	EMI FERRITE BEAD	3.2x1.6x1.6mm 0.2A	MURATA	BLM 32 A06 PT/Ø180 REEL REEL a 3000 STK	370.021
FP10-2	EMI FERRITE BEAD	3.2x1.6x1.6mm 0.2A	MURATA	BLM 32 A06 PT/Ø180 REEL REEL a 3000 STK	370.021
FP11-2	EMI FERRITE BEAD	3.2x1.6x1.6mm 0.2A	MURATA	BLM 32 A06 PT/Ø180 REEL REEL a 3000 STK	370.021
FP12-2	EMI FERRITE BEAD	3.2x1.6x1.6mm 0.2A	MURATA	BLM 32 A06 PT/Ø180 REEL	370.021

92/47

## 7 PARTS LIST

RM2042

POSITION	DESCRIPTION		MANUFACTOR	TYPE	S.P.NUMBER
FP13-2	EMI FERRITE BEAD	3.2x1.6x1.6mm 0.2A	MURATA	REEL a 3000 STK BLM 32 A06 PT/Ø180 REEL	370.021
FP14-2	EMI FERRITE BEAD	3.2x1.6x1.6mm 0.2A	MURATA	REEL a 3000 STK BLM 32 A06 PT/Ø180 REEL	370.021
FP15-2	EMI FERRITE BEAD	3.2x1.6x1.6mm 0.2A	MURATA	REEL a 3000 STK BLM 32 A06 PT/Ø180 REEL	370.021
FP16-2	EMI FERRITE BEAD	3.2x1.6x1.6mm 0.2A	MURATA	REEL a 3000 STK BLM 32 A06 PT/Ø180 REEL	370.021
FP17-2	EMI FERRITE BEAD	3.2x1.6x1.6mm 0.2A	MURATA	REEL a 3000 STK BLM 32 A06 PT/Ø180 REEL	370.021
FP18-2	EMI FERRITE BEAD	3.2x1.6x1.6mm 0.2A	MURATA	REEL a 3000 STK BLM 32 A06 PT/Ø180 REEL	370.021
FP19-2	EMI FERRITE BEAD	3.2x1.6x1.6mm 0.2A	MURATA	REEL a 3000 STK BLM 32 A06 PT/Ø180 REEL	370.021
FP20-2	EMI FERRITE BEAD	3.2x1.6x1.6mm 0.2A	MURATA	REEL a 3000 STK BLM 32 A06 PT/Ø180 REEL	370.021
FP21-2	EMI FERRITE BEAD	3.2x1.6x1.6mm 0.2A	MURATA	REEL a 3000 STK BLM 32 A06 PT/Ø180 REEL	370.021
FP22-2	EMI FERRITE BEAD	3.2x1.6x1.6mm 0.2A	MURATA	REEL a 3000 STK BLM 32 A06 PT/Ø180 REEL	370.021
FP23-2	EMI FERRITE BEAD	3.2x1.6x1.6mm 0.2A	MURATA	REEL a 3000 STK BLM 32 A06 PT/Ø180 REEL	370.021
FP24-2	EMI FERRITE BEAD	3.2x1.6x1.6mm 0.2A	MURATA	REEL a 3000 STK BLM 32 A06 PT/Ø180 REEL	370.021
J1-2	SOCKET 2x8 POLES	1/20" PCB VERSION	AMP	4-175639-6	376.006
J2-2	SOCKET	2x7 POLES	AMP	1-215079-4	78.196
J3-2	SOCKET 2x8 POLES	1/20" PCB VERSION	AMP	4-175639-6	376.006
J4-2	SOCKET	20 POLES PCB VERSION	AMP	2-215079-0	78.198
J5-2	SOCKET 2x8 POLES	1/20" PCB VERSION	AMP	4-175639-6	376.006
J6-2	SOCKET 2x8 POLES	1/20" PCB VERSION	AMP	4-175639-6	376.006
L1-2	CHOKE FIXED	1u0H 10%	FASTRON	MICC-1R0K-02	20.347
Q1-2	TRANSISTOR LF	BC848B NPN SMD	PHILIPS	BC848B	345.048
Q2-2	TRANSISTOR LF	BC848B NPN SMD	PHILIPS	BC848B	345.048
Q3-2	TRANSISTOR LF	BC858B NPN SMD	PHILIPS	BC858B	345.058
R1-2	RESISTOR SMD 0805	10k OHM 5% 0.1W	ROHM	MCR 10 JZO J 103 E	302.060
R2-2	RESISTOR SMD 0805	10k OHM 5% 0.1W	ROHM	REEL a 5000 STK MCR 10 JZO J 103 E	302.060
R3-2	RESISTOR SMD 0805	270k OHM 5% 0.1W	ROHM	REEL a 5000 STK MCR 10 JZO J 274 E	302.077
R4-2	RESISTOR SMD 0805	1M0 OHM 5% 0.1W	ROHM	REEL a 5000 STK MCR 10 JZO J 105 E	302.084
R5-2	RESISTOR SMD 0805	1M0 OHM 5% 0.1W	ROHM	REEL a 5000 STK MCR 10 JZO J 105 E	302.084
R6-2	RESISTOR SMD 0805	4k7 OHM 5% 0.1W	ROHM	REEL a 5000 STK MCR 10 JZO J 472 E	302.056
R7-2	RESISTOR SMD 0805	4k7 OHM 5% 0.1W	ROHM	REEL a 5000 STK MCR 10 JZO J 472 E	302.056
R8-2	RESISTOR SMD 0805	4k7 OHM 5% 0.1W	ROHM	REEL a 5000 STK MCR 10 JZO J 472 E	302.056
R9-2	RESISTOR SMD 0805	4k7 OHM 5% 0.1W	ROHM	REEL a 5000 STK MCR 10 JZO J 472 E	302.056
R10-2	RESISTOR SMD 0805	4k7 OHM 5% 0.1W	ROHM	REEL a 5000 STK MCR 10 JZO J 472 E	302.056
R11-2	RESISTOR SMD 0805	56k OHM 5% 0.1W	ROHM	REEL a 5000 STK MCR 10 JZO J 563 E	302.069
R12-2	RESISTOR SMD 0805	100k OHM 5% 0.1W	ROHM	REEL a 5000 STK MCR 10 JZO J 104 E	302.072
R13-2	RESISTOR SMD 0805	10k OHM 5% 0.1W	ROHM	REEL a 5000 STK MCR 10 JZO J 103 E	302.060
R14-2	RESISTOR SMD 0805	56k OHM 5% 0.1W	ROHM	REEL a 5000 STK MCR 10 JZO J 563 E	302.069
R15-2	RESISTOR SMD 0805	100k OHM 5% 0.1W	ROHM	REEL a 5000 STK MCR 10 JZO J 104 E	302.072
R16-2	RESISTOR SMD 0805	10k OHM 5% 0.1W	ROHM	REEL a 5000 STK MCR 10 JZO J 103 E	302.060
R17-2	RESISTOR SMD 0805	4k7 OHM 5% 0.1W	ROHM	REEL a 5000 STK MCR 10 JZO J 472 E	302.056
R18-2	RESISTOR SMD 0805	4k7 OHM 5% 0.1W	ROHM	REEL a 5000 STK MCR 10 JZO J 472 E	302.056

92/47

7 PARTS LIST

RM2042

POSITION	DESCRIPTION		MANUFACTOR	TYPE	S.P.NUMBER
R19-2	RESISTOR SMD 0805	10k OHM 5% 0.1W	ROHM	MCR 10 JZO J 103 E REEL a 5000 STK	302.060
R20-2	RESISTOR SMD 0805	10k OHM 5% 0.1W	ROHM	MCR 10 JZO J 103 E REEL a 5000 STK	302.060
R21-2	RESISTOR SMD 0805	2k2 OHM 5% 0.1W	ROHM	MCR 10 JZO J 222 E REEL a 5000 STK	302.052
R22-2	RESISTOR SMD 0805	2k2 OHM 5% 0.1W	ROHM	MCR 10 JZO J 222 E REEL a 5000 STK	302.052
R23-2	RESISTOR SMD 0805	10k OHM 5% 0.1W	ROHM	MCR 10 JZO J 103 E REEL a 5000 STK	302.060
R24-2	RESISTOR SMD 0805	4k7 OHM 5% 0.1W	ROHM	MCR 10 JZO J 472 E REEL a 5000 STK	302.056
R25-2	RESISTOR SMD 0805	10k OHM 5% 0.1W	ROHM	MCR 10 JZO J 103 E REEL a 5000 STK	302.060
R26-2	RESISTOR SMD 0805	100 OHM 5% 0.1W	ROHM	MCR 10 JZO J 101 E REEL a 5000 STK	302.036
R27-2	RESISTOR SMD 0805	100 OHM 5% 0.1W	ROHM	MCR 10 JZO J 101 E REEL a 5000 STK	302.036
R28-2	RESISTOR SMD 0805	100 OHM 5% 0.1W	ROHM	MCR 10 JZO J 101 E REEL a 5000 STK	302.036
R29-2	RESISTOR SMD 0805	100 OHM 5% 0.1W	ROHM	MCR 10 JZO J 101 E REEL a 5000 STK	302.036
R30-2	RESISTOR SMD 0805	100 OHM 5% 0.1W	ROHM	MCR 10 JZO J 101 E REEL a 5000 STK	302.036
R31-2	RESISTOR SMD 0805	100 OHM 5% 0.1W	ROHM	MCR 10 JZO J 101 E REEL a 5000 STK	302.036
R32-2	RESISTOR SMD 0805	100 OHM 5% 0.1W	ROHM	MCR 10 JZO J 101 E REEL a 5000 STK	302.036
R33-2	RESISTOR SMD 0805	10k OHM 5% 0.1W	ROHM	MCR 10 JZO J 103 E REEL a 5000 STK	302.060
S1-2	INTEGRATED CIRCUIT		COPAL*	CS-4-12YTA REEL a 500 STK	373.100
U1-2	INTEGRATED CIRCUIT	28C64	CATALYST	CAT28C64AN-20	356.210
U2-2	STATIC RAM	8kx8 Taa=150nSec	OKI	MSM 5165AL GS-15(-12,-10)	356.310
U3-2	PROGRAMMED PROM U3-2	RM2042 (C1109,"ODD")	S.P. RADIO A/S	0-0-28221 / C1109-4200	728221
U4-2	STATIC RAM	8kx8 Taa=150nSec	OKI	MSM 5165AL GS-15(-12,-10)	356.310
U5-2	PROGRAMMED PROM U5-2	RM2042 (C1110,"EVEN")	S.P. RADIO A/S	0-0-28222 / C1110-FC65	728222
U6-2	INTEGRATED CIRCUIT	68HC000	TEXAS*	MC68HC000FN8	356.000
U7-2	INTEGRATED CIRCUIT	74HC32D	TEXAS*	SN74HC32D	355.217
U8-2	INTEGRATED CIRCUIT	74HC32D	TEXAS*	SN74HC32D	355.217
U9-2	INTEGRATED CIRCUIT	74HC32D	TEXAS*	SN74HC32D	355.217
U10-2	INTEGRATED CIRCUIT	74HC04D	TEXAS*	SN74HC04D	355.205
U11-2	INTEGRATED CIRCUIT	74HC21D	TEXAS*	SN74HC21D	355.214
U12-2	INTEGRATED CIRCUIT	74HC00D	TEXAS*	SN74HC00D	355.200
U13-2	INTEGRATED CIRCUIT	74HC08D	TEXAS*	SN74HC08D	355.208
U14-2	INTEGRATED CIRCUIT	74HC393D	TEXAS*	SN74HC393D	355.281
U15-2	INTEGRATED CIRCUIT	74HC05D	TEXAS*	SN74HC05D	355.207
U16-2	INTEGRATED CIRCUIT	74HC04D	TEXAS*	SN74HC04D	355.205
U17-2	INTEGRATED CIRCUIT	74HC148	SGS-THOMSON*	SN74HC148M1	355.237
U18-2	INTEGRATED CIRCUIT	74HC74D	TEXAS*	SN74HC74D	355.223
U19-2	INTEGRATED CIRCUIT	74HC32D	TEXAS*	SN74HC32D	355.217
U20-2	INTEGRATED CIRCUIT	74HC4040	SGS-THOMSON*	SN74HC4040M1	355.307
U21-2	INTEGRATED CIRCUIT	74HC74D	TEXAS*	SN74HC74D	355.223
U22-2	INTEGRATED CIRCUIT	82C55	OKI	M82C55A-2V	356.616
U23-2	INTEGRATED CIRCUIT	74HC138D	TEXAS*	SN74HC138D	355.235
U24-2	INTEGRATED CIRCUIT	74HC154	MOTOROLA*	MC74HC154DW	355.239
U25-2	INTEGRATED CIRCUIT	74HC4040	SGS-THOMSON*	SN74HC4040M1	355.307
U26-2	INTEGRATED CIRCUIT	82C51	OKI*	MSM82C51A-2JS	356.610
U27-2	INTEGRATED CIRCUIT	82C54	OKI*	MSM82C54JS	356.614
U28-2	INTEGRATED CIRCUIT	74HC08D	TEXAS*	SN74HC08D	355.208
U29-2	INTEGRATED CIRCUIT	74HC74D	TEXAS*	SN74HC74D	355.223
U30-2	INTEGRATED CIRCUIT	74HC74D	TEXAS*	SN74HC74D	355.223
U31-2	INTEGRATED CIRCUIT	DP8573A	NATIONAL*	DP8573AV	356.630
U32-2	INTEGRATED CIRCUIT	LTC1044	LINEAR TECHNOLO	LTC1044CS8	350.010
U33-2	INTEGRATED CIRCUIT	74HC74D	TEXAS*	SN74HC74D	355.223
U34-2	INTEGRATED CIRCUIT	74HC08D	TEXAS*	SN74HC08D	355.208
X1-2	CRYSTAL	8.000MHz HC-49/U	NDK	LN-P-0002 8.000MHz Clod = 20pF	39.771
X2-2	CRYSTAL	4.9152 MHz HC-49/U	NDK	LN-P-0001 4.9152MHz Clod = 20pF	39.769
X3-2	CRYSTAL	32.768kHz Ø2x6mm	NDK	MU-206S	39.765

92/47

POSITION	DESCRIPTION	MANUFACTURER	TYPE	S.P.NUMBER	
<b>RECEIVER (MODULE 3) RM204</b>		<b>RM2042</b>	<b>ESPERA</b>	<b>5-0-26943D / 4-0-26943I</b>	<b>626943</b>
POSITION	DESCRIPTION	MANUFACTURER	TYPE	S.P.NUMBER	
C1-3	CAPACITOR CERAM. SMD 1206	MURATA	GRM42-6 X7R 102 K 500 PT	324.688	
C2-3	CAPACITOR CERAM. SMD 0805	MURATA	GRM40 COG 2R7 C 50 PT REEL a 4000 STK	323.067	
C3-3	CAPACITOR CERAM. SMD 0805	MURATA	GRM40 COG 010 C 50 PT REEL a 4000 STK	323.062	
C4-3	CAPACITOR CERAM. SMD 1206	MURATA	GRM42-6 X7R 102 K 500 PT	324.688	
C5-3	CAPACITOR CERAM. SMD 1206	MURATA	GRM42-6 COG 2R2 C 500 PT	324.266	
C6-3	CAPACITOR CERAM. SMD 1206	MURATA	GRM42-6 COG 3R3 C 500 PT	324.268	
C7-3	CAPACITOR CERAM. SMD 0805	MURATA	GRM40 P2H 6R8 C 50 PT REEL a 4000 STK	323.472	
C8-3	CAPACITOR CERAM. SMD 0805	MURATA	GRM40 P2H 5R6 C 50 PT REEL a 4000 STK	323.471	
C9-3	CAPACITOR CERAM. SMD 0805	MURATA	GRM40 COG 180 J 50 PT REEL a 4000 STK	323.077	
C10-3	CAPACITOR CERAM. SMD 0805	MURATA	GRM40 X7R 102 K 50 PT REEL a 4000 STK	328.324	
C11-3	CAPACITOR CERAM. SMD 0805	MURATA	GRM40 X7R 102 K 50 PT REEL a 4000 STK	328.324	
C12-3	CAPACITOR CERAM. SMD 0805	MURATA	GRM40 X7R 102 K 50 PT REEL a 4000 STK	328.324	
C13-3	CAPACITOR CERAM. SMD 0805	MURATA	GRM40 COG 560 J 50 PT REEL a 4000 STK	323.083	
C14-3	CAPACITOR CERAM. SMD 0805	MURATA	GRM40 X7R 102 K 50 PT REEL a 4000 STK	328.324	
C15-3	CAPACITOR CERAM. SMD 0805	MURATA	GRM40 P2H 120 J 50 PT REEL a 4000 STK	323.475	
C16-3	CAPACITOR CERAM. SMD 0805	MURATA	GRM40 P2H 3R3 C 50 PT REEL a 4000 STK	323.468	
C17-3	CAPACITOR CERAM. SMD 0805	MURATA	GRM40 P2H 8R2 C 50 PT REEL a 4000 STK	323.473	
C18-3	CAPACITOR CERAM. SMD 0805	MURATA	GRM40 P2H 8R2 C 50 PT REEL a 4000 STK	323.473	
C19-3	CAPACITOR CERAM. SMD 0805	MURATA	GRM40 P2H 3R3 C 50 PT REEL a 4000 STK	323.468	
C20-3	CAPACITOR CERAM. SMD 0805	MURATA	GRM40 P2H 120 J 50 PT REEL a 4000 STK	323.475	
C21-3	CAPACITOR CERAM. SMD 0805	MURATA	GRM40 X7R 103 K 50 PT REEL a 4000 STK	328.336	
C22-3	CAPACITOR CERAM. SMD 0805	MURATA	GRM40 X7R 103 K 50 PT REEL a 4000 STK	328.336	
C23-3	CAPACITOR CERAM. SMD 0805	MURATA	GRM40 COG 560 J 50 PT REEL a 4000 STK	323.083	
C24-3	CAPACITOR CERAM. SMD 0805	MURATA	GRM40 P2H 330 J 50 PT REEL a 4000 STK	323.480	
C25-3	CAPACITOR CERAM. SMD 0805	MURATA	GRM40 COG 2R7 C 50 PT REEL a 4000 STK	323.067	
C26-3	CAPACITOR CERAM. SMD 0805	MURATA	GRM40 X7R 103 K 50 PT REEL a 4000 STK	328.336	
C27-3	CAPACITOR CERAM. SMD 0805	MURATA	GRM40 X7R 103 K 50 PT REEL a 4000 STK	328.336	
C28-3	CAPACITOR CERAM. SMD 0805	MURATA	GRM40 X7R 103 K 50 PT REEL a 4000 STK	328.336	
C29-3	CAPACITOR CERAM. SMD 0805	MURATA	GRM40 X7R 103 K 50 PT REEL a 4000 STK	328.336	
C30-3	CAPACITOR CERAM. SMD 1206	MURATA	GRM42-6 X7R 102 K 500 PT	324.688	
C31-3	CAPACITOR CERAM. SMD 0805	MURATA	GRM40 P2H 330 J 50 PT REEL a 4000 STK	323.480	
C32-3	CAPACITOR CERAM. SMD 0805	MURATA	GRM40 X7R 103 K 50 PT REEL a 4000 STK	328.336	
C33-3	CAPACITOR CERAM. SMD 0805	MURATA	GRM40 COG 271 J 50 PT REEL a 4000 STK	323.091	
C34-3	CAPACITOR TRIMMER SMD	MURATA	TZB04Z250BA	335.024	
C35-3	CAPACITOR CERAM. SMD 0805	MURATA	GRM40 COG 560 J 50 PT REEL a 4000 STK	323.083	
C36-3	CAPACITOR CERAM. SMD 0805	MURATA	GRM40 COG 560 J 50 PT	323.083	

## 7 PARTS LIST

RM2042

POSITION	DESCRIPTION		MANUFACTOR	TYPE	S.P.NUMBER
C37-3	CAPACITOR CERAM. SMD 0805	100nF 10% X7R 25VDC	MURATA	REEL a 4000 STK GRM40 X7R 104 K 25 PT	328.348
C38-3	CAPACITOR CERAM. SMD 0805	100nF 10% X7R 25VDC	MURATA	REEL a 3000 STK GRM40 X7R 104 K 25 PT	328.348
C39-3	CAPACITOR CERAM. SMD 0805	56pF 5% NPO 50VDC	MURATA	REEL a 3000 STK GRM40 COG 560 J 50 PT	323.083
C40-3	CAPACITOR CERAM. SMD 0805	100nF 10% X7R 25VDC	MURATA	REEL a 4000 STK GRM40 X7R 104 K 25 PT	328.348
C41-3	CAPACITOR ELECTROLYTIC SM	10uF 20% 16VDC	PANASONIC	REEL a 3000 STK ECE V 1C V 100 S R	333.079
C42-3	CAPACITOR CERAM. SMD 0805	100nF 10% X7R 25VDC	MURATA	REEL a 2000 STK GRM40 X7R 104 K 25 PT	328.348
C43-3	CAPACITOR CERAM. SMD 0805	22nF 10% X7R 50VDC	MURATA	REEL a 3000 STK GRM40 X7R 223 K 50 PT	328.340
C44-3	CAPACITOR CERAM. SMD 1206	3n9 5% NPO 50VDC	MURATA	REEL a 3000 STK GRM42-6COG392J 50PT10	324.105
C45-3	CAPACITOR CERAM. SMD 1206	3n9 5% NPO 50VDC	MURATA	GRM42-6COG392J 50PT10	324.105
C46-3	CAPACITOR CERAM. SMD 0805	10nF 10% X7R 50VDC	MURATA	REEL a 4000 STK GRM40 X7R 103 K 50 PT	328.336
C47-3	CAPACITOR CERAM. SMD 0805	100nF 10% X7R 25VDC	MURATA	REEL a 3000 STK GRM40 X7R 104 K 25 PT	328.348
C48-3	CAPACITOR CERAM. SMD 0805	100nF 10% X7R 25VDC	MURATA	REEL a 3000 STK GRM40 X7R 104 K 25 PT	328.348
C49-3	CAPACITOR CERAM. SMD 0805	100nF 10% X7R 25VDC	MURATA	REEL a 3000 STK GRM40 X7R 104 K 25 PT	328.348
C50-3	CAPACITOR CERAM. SMD 0805	100nF 10% X7R 25VDC	MURATA	REEL a 3000 STK GRM40 X7R 104 K 25 PT	328.348
C51-3	CAPACITOR CERAM. SMD 0805	220pF 5% NPO 50VDC	MURATA	REEL a 4000 STK GRM40 COG 221 J 50 PT	323.090
C52-3	CAPACITOR ELECTROLYTIC SM	10uF 20% 16VDC	PANASONIC	REEL a 2000 STK ECE V 1C V 100 S R	333.079
C53-3	CAPACITOR ELECTROLYTIC SM	10uF 20% 16VDC	PANASONIC	REEL a 2000 STK ECE V 1C V 100 S R	333.079
C56-3	CAPACITOR CERAM. SMD 0805	100nF 10% X7R 25VDC	MURATA	REEL a 2000 STK GRM40 X7R 104 K 25 PT	328.348
C57-3	CAPACITOR CERAM. SMD 0805	1n0F 10% X7R 50VDC	MURATA	REEL a 3000 STK GRM40 X7R 102 K 50 PT	328.324
C58-3	CAPACITOR ELECTROLYTIC SM	10uF 20% 16VDC	PANASONIC	REEL a 4000 STK ECE V 1C V 100 S R	333.079
C59-3	CAPACITOR CERAM. SMD 1206	3n9 5% NPO 50VDC	MURATA	REEL a 2000 STK GRM42-6COG392J 50PT10	324.105
C60-3	CAPACITOR CERAM. SMD 1206	3n9 5% NPO 50VDC	MURATA	GRM42-6COG392J 50PT10	324.105
C61-3	CAPACITOR CERAM. SMD 0805	100nF 10% X7R 25VDC	MURATA	REEL a 3000 STK GRM40 X7R 104 K 25 PT	328.348
C62-3	CAPACITOR CERAM. SMD 0805	10nF 10% X7R 50VDC	MURATA	REEL a 4000 STK GRM40 X7R 103 K 50 PT	328.336
C63-3	CAPACITOR CERAM. SMD 0805	330pF 5% NPO 50VDC	MURATA	REEL a 3000 STK GRM40 COG 331 J 50 PT	323.092
C64-3	CAPACITOR CERAM. SMD 0805	10nF 10% X7R 50VDC	MURATA	REEL a 4000 STK GRM40 X7R 103 K 50 PT	328.336
C65-3	CAPACITOR CERAM. SMD 1206	1n5 5% NPO 50VDC	MURATA	REEL a 4000 STK GRM42-6COG152	324.100
C66-3	CAPACITOR CERAM. SMD 0805	100nF 10% X7R 25VDC	MURATA	REEL a 3000 STK GRM40 X7R 104 K 25 PT	328.348
C68-3	CAPACITOR CERAM. SMD 0805	100nF 10% X7R 25VDC	MURATA	REEL a 3000 STK GRM40 X7R 104 K 25 PT	328.348
C69-3	CAPACITOR ELECTROLYTIC SM	10uF 20% 16VDC	PANASONIC	REEL a 3000 STK ECE V 1C V 100 S R	333.079
C70-3	CAPACITOR CERAM. SMD 0805	100nF 10% X7R 25VDC	MURATA	REEL a 2000 STK GRM40 X7R 104 K 25 PT	328.348
C71-3	CAPACITOR ELECTROLYTIC SM	3u3F 20% 50VDC	PANASONIC	REEL a 3000 STK ECE V 1H V 3R3 S R	333.073
C72-3	CAPACITOR ELECTROLYTIC SM	10uF 20% 16VDC	PANASONIC	REEL a 2000 STK ECE V 1C V 100 S R	333.079
C73-3	CAPACITOR TANTALUM 3528	2u2F 20% 16VDC	PANASONIC	REEL a 2000 STK ECSH 1C X 225 R	334.028
C74-3	CAPACITOR CERAM. SMD 0805	10nF 10% X7R 50VDC	MURATA	REEL a 2000 STK GRM40 X7R 103 K 50 PT	328.336
C75-3	CAPACITOR CERAM. SMD 0805	p47F +/-0.25pF NPO 50VDC	MURATA	REEL a 4000 STK GRM40 COG R47 C 50 PT	323.058
C76-3	CAPACITOR CERAM. SMD 0805	p56F +/- 0.25p NPO 50VDC	MURATA	REEL a 4000 STK GRM40 COG R56 C 50 PT	323.059
C77-3	CAPACITOR CERAM. SMD 0805	1n0F 10% X7R 50VDC	MURATA	REEL a 4000 STK GRM40 X7R 102 K 50 PT	328.324

93/12



## 7 PARTS LIST

RM2042

POSITION	DESCRIPTION		MANUFACTOR	TYPE	S.P.NUMBER
C78-3	CAPACITOR CERAM. SMD 0805	1n0F 10% X7R 50VDC	MURATA	REEL a 4000 STK GRM40 X7R 102 K 50 PT	328.324
C79-3	CAPACITOR CERAM. SMD 0805	1n0F 10% X7R 50VDC	MURATA	REEL a 4000 STK GRM40 X7R 102 K 50 PT	328.324
C80-3	CAPACITOR CERAM. SMD 0805	18pF 5% N150 50VDC	MURATA	REEL a 4000 STK GRM40 P2H 180 J 50 PT	323.477
C81-3	CAPACITOR CERAM. SMD 0805	27pF 5% N150 50VDC	MURATA	REEL a 4000 STK GRM40 P2H 270 J 50 PT	323.479
C82-3	CAPACITOR CERAM. SMD 0805	56pF 5% N150 50VDC	MURATA	REEL a 4000 STK GRM40 P2H 560 J 50 PT	323.483
C83-3	CAPACITOR CERAM. SMD 0805	1n0F 10% X7R 50VDC	MURATA	REEL a 4000 STK GRM40 X7R 102 K 50 PT	328.324
C84-3	CAPACITOR CERAM. SMD 0805	1n0F 10% X7R 50VDC	MURATA	REEL a 4000 STK GRM40 X7R 102 K 50 PT	328.324
C85-3	CAPACITOR CERAM. SMD 0805	1n0F 10% X7R 50VDC	MURATA	REEL a 4000 STK GRM40 X7R 102 K 50 PT	328.324
C86-3	CAPACITOR CERAM. SMD 0805	1n0F 10% X7R 50VDC	MURATA	REEL a 4000 STK GRM40 X7R 102 K 50 PT	328.324
C87-3	CAPACITOR CERAM. SMD 0805	1n0F 10% X7R 50VDC	MURATA	REEL a 4000 STK GRM40 X7R 102 K 50 PT	328.324
C88-3	CAPACITOR CERAM. SMD 0805	1n0F 10% X7R 50VDC	MURATA	REEL a 4000 STK GRM40 X7R 102 K 50 PT	328.324
C89-3	CAPACITOR CERAM. SMD 0805	10pF 5% N150 50VDC	MURATA	REEL a 4000 STK GRM40 P2H 100 D 50 PT	323.474
C90-3	CAPACITOR CERAM. SMD 0805	39pF 5% N150 50VDC	MURATA	REEL a 4000 STK GRM40 P2H 390 J 50 PT	323.481
C91-3	CAPACITOR CERAM. SMD 0805	1n0F 10% X7R 50VDC	MURATA	REEL a 4000 STK GRM40 X7R 102 K 50 PT	328.324
C92-3	CAPACITOR CERAM. SMD 0805	270pF 5% NPO 50VDC	MURATA	REEL a 4000 STK GRM40 COG 271 J 50 PT	323.091
C93-3	CAPACITOR CERAM. SMD 0805	27pF 5% NPO 50VDC	MURATA	REEL a 4000 STK GRM40 COG 270 J 50 PT	323.079
C94-3	CAPACITOR CERAM. SMD 0805	270pF 5% NPO 50VDC	MURATA	REEL a 4000 STK GRM40 COG 271 J 50 PT	323.091
C95-3	CAPACITOR CERAM. SMD 0805	100nF 10% X7R 25VDC	MURATA	REEL a 4000 STK GRM40 X7R 104 K 25 PT	328.348
C96-3	CAPACITOR CERAM. SMD 0805	150pF 5% NPO 50VDC	MURATA	REEL a 3000 STK GRM40 COG 151 J 50 PT	323.088
C97-3	CAPACITOR CERAM. SMD 1206	1n5 5% NPO 50VDC	MURATA	REEL a 4000 STK GRM42-6COG152	324.100
C98-3	CAPACITOR CERAM. SMD 0805	100nF 10% X7R 25VDC	MURATA	REEL a 3000 STK GRM40 X7R 104 K 25 PT	328.348
C99-3	CAPACITOR CERAM. SMD 0805	100nF 10% X7R 25VDC	MURATA	REEL a 3000 STK GRM40 X7R 104 K 25 PT	328.348
C100-3	CAPACITOR CERAM. SMD 0805	100nF 10% X7R 25VDC	MURATA	REEL a 3000 STK GRM40 X7R 104 K 25 PT	328.348
C101-3	CAPACITOR CERAM. SMD 1206	3n9 5% NPO 50VDC	MURATA	REEL a 3000 STK GRM42-6COG392J 50PT10	324.105
C102-3	CAPACITOR CERAM. SMD 1206	3n9 5% NPO 50VDC	MURATA	GRM42-6COG392J 50PT10	324.105
C103-3	CAPACITOR CERAM. SMD 1206	3n9 5% NPO 50VDC	MURATA	GRM42-6COG392J 50PT10	324.105
C104-3	CAPACITOR CERAM. SMD 1206	3n9 5% NPO 50VDC	MURATA	GRM42-6COG392J 50PT10	324.105
C105-3	CAPACITOR CERAM. SMD 1206	3n9 5% NPO 50VDC	MURATA	GRM42-6COG392J 50PT10	324.105
C106-3	CAPACITOR CERAM. SMD 1206	3n9 5% NPO 50VDC	MURATA	GRM42-6COG392J 50PT10	324.105
C107-3	CAPACITOR CERAM. SMD 1206	3n9 5% NPO 50VDC	MURATA	GRM42-6COG392J 50PT10	324.105
C108-3	CAPACITOR CERAM. SMD 1206	3n9 5% NPO 50VDC	MURATA	GRM42-6COG392J 50PT10	324.105
C109-3	CAPACITOR CERAM. SMD 1206	3n9 5% NPO 50VDC	MURATA	GRM42-6COG392J 50PT10	324.105
C110-3	CAPACITOR CERAM. SMD 1206	3n9 5% NPO 50VDC	MURATA	GRM42-6COG392J 50PT10	324.105
C111-3	CAPACITOR CERAM. SMD 0805	100nF 10% X7R 25VDC	MURATA	REEL a 3000 STK GRM40 X7R 104 K 25 PT	328.348
C112-3	CAPACITOR CERAM. SMD 0805	100nF 10% X7R 25VDC	MURATA	REEL a 3000 STK GRM40 X7R 104 K 25 PT	328.348
C113-3	CAPACITOR CERAM. SMD 0805	100nF 10% X7R 25VDC	MURATA	REEL a 3000 STK GRM40 X7R 104 K 25 PT	328.348
C114-3	CAPACITOR CERAM. SMD 0805	68pF 5% NPO 50VDC	MURATA	REEL a 4000 STK GRM40 COG 680 J 50 PT	323.084
C115-3	CAPACITOR CERAM. SMD 0805	330pF 5% NPO 50VDC	MURATA	REEL a 4000 STK GRM40 COG 331 J 50 PT	323.092
C116-3	CAPACITOR ELECTROLYTIC SM	3u3F 20% 50VDC	PANASONIC	REEL a 2000 STK ECE V 1H V 3R3 S R	333.073
C117-3	CAPACITOR ELECTROLYTIC SM	3u3F 20% 50VDC	PANASONIC	REEL a 2000 STK ECE V 1H V 3R3 S R	333.073
C118-3	CAPACITOR ELECTROLYTIC SM	3u3F 20% 50VDC	PANASONIC	REEL a 2000 STK ECE V 1H V 3R3 S R	333.073

93/12

## 7 PARTS LIST

RM2042

POSITION	DESCRIPTION		MANUFACTURER	TYPE	S.P.NUMBER
C119-3	CAPACITOR CERAM. SMD 1206	3n9 5% NPO 50VDC	MURATA	REEL a 2000 STK GRM42-6COG392J 50PT10	324.105
C120-3	CAPACITOR ELECTROLYTIC SM	10uF 20% 16VDC	PANASONIC	ECE V 1C V 100 S R	333.079
C121-3	CAPACITOR CERAM. SMD 0805	1n0F 10% X7R 50VDC	MURATA	REEL a 2000 STK GRM40 X7R 102 K 50 PT	328.324
C122-3	CAPACITOR CERAM. SMD 0805	270pF 5% NPO 50VDC	MURATA	REEL a 4000 STK GRM40 COG 271 J 50 PT	323.091
C123-3	CAPACITOR CERAM. SMD 0805	27pF 5% NPO 50VDC	MURATA	REEL a 4000 STK GRM40 COG 270 J 50 PT	323.079
C124-3	CAPACITOR CERAM. SMD 0805	270pF 5% NPO 50VDC	MURATA	REEL a 4000 STK GRM40 COG 271 J 50 PT	323.091
C125-3	CAPACITOR CERAM. SMD 0805	100nF 10% X7R 25VDC	MURATA	REEL a 3000 STK GRM40 X7R 104 K 25 PT	328.348
C126-3	CAPACITOR CERAM. SMD 0805	150pF 5% NPO 50VDC	MURATA	REEL a 4000 STK GRM40 COG 151 J 50 PT	323.088
C127-3	CAPACITOR CERAM. SMD 1206	1n5 5% NPO 50VDC	MURATA	REEL a 4000 STK GRM42-6COG152	324.100
C128-3	CAPACITOR CERAM. SMD 0805	100nF 10% X7R 25VDC	MURATA	GRM40 X7R 104 K 25 PT	328.348
C129-3	CAPACITOR CERAM. SMD 0805	100nF 10% X7R 25VDC	MURATA	REEL a 3000 STK GRM40 X7R 104 K 25 PT	328.348
C130-3	CAPACITOR CERAM. SMD 0805	100nF 10% X7R 25VDC	MURATA	REEL a 3000 STK GRM40 X7R 104 K 25 PT	328.348
D1-3	DIODE	BAS32L	PHILIPS	BAS32L	340.032
D2-3	DIODE	BAS32L	PHILIPS	BAS32L	340.032
D3-3	DIODE SCHOTTKY	BAT 54S	PHILIPS	BAT 54 S	340.310
D4-3	DIODE SCHOTTKY	BAT 54S	PHILIPS	BAT 54 S	340.310
FL1-3	CRYSTAL FILTER	Fc=15.3MHz	* NDK	SP.SPEC: C1076 (15N15B)	40.029
FL2-3	CERAMIC FILTER	Fc=450kHz BW=20kHz	MURATA	SFR450D	41.513
J1-3	ANTENNA JACK (FEMALE)	SO239	KAJ V HANSEN	SO239	78.504
J2-3	SOCKET 2x8 POLES	1/20" PCB VERSION	AMP	4-175639-6	376.006
L1-3	COIL RF	0.11uH ADJUSTABLE	TOKO	E526HN-100117	38.409
L2-3	COIL RF	0.11uH ADJUSTABLE	TOKO	E526HN-100117	38.409
L3-3	COIL RF	0.11uH ADJUSTABLE	TOKO	E526HN-100117	38.409
L4-3	COIL RF	0.11uH ADJUSTABLE	TOKO	E526HN-100117	38.409
L5-3	CHOKER FIXED	3u3H 5%	COILCRAFT	1008CS-332-XJBC	337.280
L6-3	TRANSFORMER RF	110nH ADJUSTABLE	TOKO	E526-110436	38.407
L7-3	CHOKER FIXED	120nH 5%	COILCRAFT	1008CS-121-XJBC	337.263
L8-3	COIL RF	68n 10%	SIEMENS	B82412-A3680-K	337.110
L9-3	CHOKER FIXED	270nH 5%	COILCRAFT	1008CS-271-XJBC	337.267
Q1-3	TRANSISTOR FET	BF996SB FET SMD	PHILIPS	BF996SB-GS08	347.096
Q2-3	TRANSISTOR N-CHAN. JFET	TIS88A1	MOTOROLA	TM 00 044 -1	29.735
Q3-3	TRANSISTOR N-CHAN. JFET	TIS88A1	MOTOROLA	TM 00 044 -1	29.735
Q4-3	TRANSISTOR FET	BF996SB FET SMD	PHILIPS	BF996SB-GS08	347.096
Q5-3	TRANSISTOR NPN SMD	BFR92A NPN SMD	PHILIPS	BFR92A	345.530
Q6-3	TRANSISTOR LF	BFR92A NPN SMD	PHILIPS	BFR92A	345.530
Q7-3	TRANSISTOR LF	BFR92A NPN SMD	PHILIPS	BFR92A	345.530
R1-3	RESISTOR MF	47k OHM 5% 0.4W	PHILIPS	2322 181 53473	01.241
R2-3	RESISTOR SMD 0805	100k OHM 5% 0.1W	ROHM	MCR 10 JZO J 104 E	302.072
R3-3	RESISTOR SMD 0805	27k OHM 5% 0.1W	ROHM	REEL a 5000 STK MCR 10 JZO J 273 E	302.065
R4-3	RESISTOR SMD 0805	12k OHM 5% 0.1W	ROHM	REEL a 5000 STK MCR 10 JZO J 123 E	302.061
R5-3	RESISTOR SMD 0805	22k OHM 5% 0.1W	ROHM	REEL a 5000 STK MCR 10 JZO J 223 E	302.064
R6-3	RESISTOR SMD 0805	100 OHM 5% 0.1W	ROHM	REEL a 5000 STK MCR 10 JZO J 101 E	302.036
R7-3	RESISTOR SMD 0805	100 OHM 5% 0.1W	ROHM	REEL a 5000 STK MCR 10 JZO J 101 E	302.036
R8-3	RESISTOR SMD 0805	330 OHM 5% 0.1W	ROHM	REEL a 5000 STK MCR 10 JZO J 331 E	302.042
R9-3	RESISTOR SMD 0805	560 OHM 5% 0.1W	ROHM	REEL a 5000 STK MCR 10 JZO J 561 E	302.045
R10-3	RESISTOR SMD 0805	560 OHM 5% 0.1W	ROHM	REEL a 5000 STK MCR 10 JZO J 561 E	302.045
R11-3	RESISTOR SMD 0805	100 OHM 5% 0.1W	ROHM	REEL a 5000 STK MCR 10 JZO J 101 E	302.036
R12-3	RESISTOR SMD 0805	100 OHM 5% 0.1W	ROHM	REEL a 5000 STK MCR 10 JZO J 101 E	302.036
R13-3	RESISTOR SMD 0805	3k92 OHM 1% 50mW	DRALORIC	REEL a 5000 STK CR 0805 K 3921 F G4	302.427

93/12

7 PARTS LIST

RM2042

POSITION	DESCRIPTION		MANUFACTOR	TYPE	S.P.NUMBER
R14-3	RESISTOR SMD 0805	475R OHM 1% 50mW	DRALORIC	REEL a 5000 STK CR 0805 K 4750 F G4	302.335
R15-3	RESISTOR SMD 0805	7k50 OHM 1% 50mW	DRALORIC	REEL a 5000 STK CR 0805 K 7501 F G4 REEL a 5000 STK	302.454
R16-3	RESISTOR SMD 0805	4k99 OHM 1% 50mW	DRALORIC	CR 0805 K 4991 F G4 REEL a 5000 STK	302.437
R17-3	RESISTOR SMD 0805	12k OHM 5% 0.1W	ROHM	MCR 10 JZO J 123 E REEL a 5000 STK	302.061
R18-3	RESISTOR SMD 0805	47k OHM 5% 0.1W	ROHM	MCR 10 JZO J 473 E	302.068
R19-3	RESISTOR SMD 0805	100 OHM 5% 0.1W	ROHM	REEL a 5000 STK MCR 10 JZO J 101 E	302.036
R20-3	RESISTOR SMD 0805	100 OHM 5% 0.1W	ROHM	REEL a 5000 STK MCR 10 JZO J 101 E REEL a 5000 STK	302.036
R21-3	RESISTOR SMD 0805	1k5 OHM 5% 0.1W	ROHM	MCR 10 JZO J 152 E	302.050
R22-3	RESISTOR SMD 0805	820 OHM 5% 0.1W	ROHM	REEL a 5000 STK MCR 10 JZO J 821 E	302.047
R23-3	RESISTOR SMD 0805	1k8 OHM 5% 0.1W	ROHM	REEL a 5000 STK MCR 10 JZO J 182 E	302.051
R24-3	RESISTOR SMD 0805	47k OHM 5% 0.1W	ROHM	REEL a 5000 STK MCR 10 JZO J 473 E	302.068
R25-3	RESISTOR SMD 0805	1k5 OHM 5% 0.1W	ROHM	REEL a 5000 STK MCR 10 JZO J 152 E REEL a 5000 STK	302.050
R26-3	RESISTOR SMD 0805	100 OHM 5% 0.1W	ROHM	MCR 10 JZO J 101 E	302.036
R27-3	RESISTOR SMD 0805	68k OHM 5% 0.1W	ROHM	REEL a 5000 STK MCR 10 JZO J 683 E	302.070
R28-3	RESISTOR SMD 0805	470k OHM 5% 0.1W	ROHM	REEL a 5000 STK MCR 10 JZO J 474 E	302.080
R29-3	RESISTOR SMD 0805	82k OHM 5% 0.1W	ROHM	REEL a 5000 STK MCR 10 JZO J 823 E	302.071
R30-3	RESISTOR SMD 0805	100k OHM 5% 0.1W	ROHM	REEL a 5000 STK MCR 10 JZO J 104 E	302.072
R31-3	RESISTOR SMD 0805	68k OHM 5% 0.1W	ROHM	REEL a 5000 STK MCR 10 JZO J 683 E	302.070
R32-3	RESISTOR SMD 0805	39k OHM 5% 0.1W	ROHM	REEL a 5000 STK MCR 10 JZO J 393 E	302.067
R33-3	RESISTOR SMD 0805	270k OHM 5% 0.1W	ROHM	REEL a 5000 STK MCR 10 JZO J 274 E	302.077
R34-3	RESISTOR SMD 0805	47k OHM 5% 0.1W	ROHM	REEL a 5000 STK MCR 10 JZO J 473 E	302.068
R35-3	RESISTOR SMD 0805	10k OHM 5% 0.1W	ROHM	REEL a 5000 STK MCR 10 JZO J 103 E REEL a 5000 STK	302.060
R36-3	PRESET SEALED	50k OHM 25% 0.1W	BOURNS	3374X-1-503-E (G) REEL a 750 STK	310.450
R38-3	RESISTOR SMD 0805	3k9 OHM 5% 0.1W	ROHM	MCR 10 JZO J 392 E REEL a 5000 STK	302.055
R39-3	RESISTOR SMD 0805	27k OHM 5% 0.1W	ROHM	MCR 10 JZO J 273 E REEL a 5000 STK	302.065
R40-3	RESISTOR SMD 0805	27k OHM 5% 0.1W	ROHM	MCR 10 JZO J 273 E REEL a 5000 STK	302.065
R41-3	RESISTOR SMD 0805	47k OHM 5% 0.1W	ROHM	MCR 10 JZO J 473 E REEL a 5000 STK	302.068
R42-3	RESISTOR SMD 0805	10k OHM 5% 0.1W	ROHM	MCR 10 JZO J 103 E REEL a 5000 STK	302.060
R43-3	RESISTOR SMD 0805	10k OHM 5% 0.1W	ROHM	MCR 10 JZO J 103 E REEL a 5000 STK	302.060
R44-3	RESISTOR SMD 0805	100k OHM 5% 0.1W	ROHM	MCR 10 JZO J 104 E REEL a 5000 STK	302.072
R46-3	RESISTOR SMD 0805	100 OHM 5% 0.1W	ROHM	MCR 10 JZO J 101 E REEL a 5000 STK	302.036
R47-3	RESISTOR SMD 0805	820 OHM 5% 0.1W	ROHM	MCR 10 JZO J 821 E REEL a 5000 STK	302.047
R48-3	RESISTOR SMD 0805	22k OHM 5% 0.1W	ROHM	MCR 10 JZO J 223 E REEL a 5000 STK	302.064
R49-3	RESISTOR SMD 0805	100k OHM 5% 0.1W	ROHM	MCR 10 JZO J 104 E REEL a 5000 STK	302.072
R50-3	RESISTOR SMD 0805	100 OHM 5% 0.1W	ROHM	MCR 10 JZO J 101 E REEL a 5000 STK	302.036

93/12

## 7 PARTS LIST

RM2042

POSITION	DESCRIPTION		MANUFACTOR	TYPE	S.P.NUMBER
R51-3	RESISTOR SMD 0805	100k OHM 5% 0.1W	ROHM	MCR 10 JZO J 104 E REEL a 5000 STK	302.072
R52-3	RESISTOR SMD 0805	33k OHM 5% 0.1W	ROHM	MCR 10 JZO J 333 E REEL a 5000 STK	302.066
R53-3	RESISTOR SMD 0805	82k OHM 5% 0.1W	ROHM	MCR 10 JZO J 823 E REEL a 5000 STK	302.071
R54-3	RESISTOR SMD 0805	10k OHM 5% 0.1W	ROHM	MCR 10 JZO J 103 E REEL a 5000 STK	302.060
R55-3	RESISTOR SMD 0805	68k OHM 5% 0.1W	ROHM	MCR 10 JZO J 683 E REEL a 5000 STK	302.070
R56-3	RESISTOR SMD 0805	39k OHM 5% 0.1W	ROHM	MCR 10 JZO J 393 E REEL a 5000 STK	302.067
R57-3	RESISTOR SMD 0805	3k9 OHM 5% 0.1W	ROHM	MCR 10 JZO J 392 E REEL a 5000 STK	302.055
R58-3	RESISTOR SMD 0805	270k OHM 5% 0.1W	ROHM	MCR 10 JZO J 274 E REEL a 5000 STK	302.077
R59-3	RESISTOR SMD 0805	121k OHM 1% 50mW	PHILIPS	2322 734 2/61214 REEL a 5000 STK	302.578
R60-3	RESISTOR SMD 0805	10k OHM 5% 0.1W	ROHM	MCR 10 JZO J 103 E REEL a 5000 STK	302.060
R61-3	RESISTOR SMD 0805	30k1 OHM 1% 50mW	PHILIPS	2322 734 2/63013 REEL a 5000 STK	302.516
R62-3	RESISTOR SMD 0805	270k OHM 5% 0.1W	ROHM	MCR 10 JZO J 274 E REEL a 5000 STK	302.077
R63-3	RESISTOR SMD 0805	68k OHM 5% 0.1W	ROHM	MCR 10 JZO J 683 E REEL a 5000 STK	302.070
R64-3	RESISTOR SMD 0805	47k OHM 5% 0.1W	ROHM	MCR 10 JZO J 473 E REEL a 5000 STK	302.068
R65-3	RESISTOR SMD 0805	47k OHM 5% 0.1W	ROHM	MCR 10 JZO J 473 E REEL a 5000 STK	302.068
R66-3	PRESET SEALED	50k OHM 25% 0.1W	BOURNS	3374X-1-503-E (G) REEL a 750 STK	310.450
R67-3	RESISTOR SMD 0805	10k OHM 5% 0.1W	ROHM	MCR 10 JZO J 103 E REEL a 5000 STK	302.060
R68-3	RESISTOR SMD 0805	100k OHM 5% 0.1W	ROHM	MCR 10 JZO J 104 E REEL a 5000 STK	302.072
R69-3	RESISTOR SMD 0805	100 OHM 5% 0.1W	ROHM	MCR 10 JZO J 101 E REEL a 5000 STK	302.036
R70-3	RESISTOR SMD 0805	22k OHM 5% 0.1W	ROHM	MCR 10 JZO J 223 E REEL a 5000 STK	302.064
R71-3	RESISTOR SMD 0805	4k7 OHM 5% 0.1W	ROHM	MCR 10 JZO J 472 E REEL a 5000 STK	302.056
C72-3	RESISTOR SMD 0805	100 OHM 5% 0.1W	ROHM	MCR 10 JZO J 101 E REEL a 5000 STK	302.036
R73-3	RESISTOR SMD 0805	2k7 OHM 5% 0.1W	ROHM	MCR 10 JZO J 272 E REEL a 5000 STK	302.053
R74-3	RESISTOR SMD 0805	330 OHM 5% 0.1W	ROHM	MCR 10 JZO J 331 E REEL a 5000 STK	302.042
R75-3	RESISTOR SMD 0805	100 OHM 5% 0.1W	ROHM	MCR 10 JZO J 101 E REEL a 5000 STK	302.036
R76-3	RESISTOR SMD 0805	3k9 OHM 5% 0.1W	ROHM	MCR 10 JZO J 392 E REEL a 5000 STK	302.055
R77-3	RESISTOR SMD 0805	4k7 OHM 5% 0.1W	ROHM	MCR 10 JZO J 472 E REEL a 5000 STK	302.056
R78-3	RESISTOR SMD 0805	100 OHM 5% 0.1W	ROHM	MCR 10 JZO J 101 E REEL a 5000 STK	302.036
R79-3	RESISTOR SMD 0805	1k0 OHM 5% 0.1W	ROHM	MCR 10 JZO J 102 E REEL a 5000 STK	302.048
R80-3	RESISTOR SMD 0805	100 OHM 5% 0.1W	ROHM	MCR 10 JZO J 101 E REEL a 5000 STK	302.036
R81-3	RESISTOR SMD 0805	2k7 OHM 5% 0.1W	ROHM	MCR 10 JZO J 272 E REEL a 5000 STK	302.053
R82-3	RESISTOR SMD 0805	2k7 OHM 5% 0.1W	ROHM	MCR 10 JZO J 272 E REEL a 5000 STK	302.053
R83-3	RESISTOR SMD 0805	100 OHM 5% 0.1W	ROHM	MCR 10 JZO J 101 E REEL a 5000 STK	302.036
R84-3	RESISTOR SMD 0805	1k0 OHM 5% 0.1W	ROHM	MCR 10 JZO J 102 E REEL a 5000 STK	302.048
R85-3	RESISTOR SMD 0805	5R6 OHM 5% 0.1W	ROHM	MCR 10 JZO J 5R6 E REEL a 5000 STK	302.021
R86-3	RESISTOR SMD 0805	680 OHM 5% 0.1W	ROHM	MCR 10 JZO J 681 E	302.046

93/12

POSITION	DESCRIPTION		MANUFACTOR	TYPE	S.P.NUMBER
R87-3	RESISTOR SMD 0805	100k OHM 5% 0.1W	ROHM	REEL a 5000 STK MCR 10 JZO J 104 E	302.072
R88-3	RESISTOR SMD 0805	270k OHM 5% 0.1W	ROHM	REEL a 5000 STK MCR 10 JZO J 274 E	302.077
R89-3	RESISTOR SMD 0805	2k2 OHM 5% 0.1W	ROHM	REEL a 5000 STK MCR 10 JZO J 222 E	302.052
R90-3	RESISTOR SMD 0805	2k2 OHM 5% 0.1W	ROHM	REEL a 5000 STK MCR 10 JZO J 222 E	302.052
R91-3	RESISTOR SMD 0805	100k OHM 5% 0.1W	ROHM	REEL a 5000 STK MCR 10 JZO J 104 E	302.072
R92-3	RESISTOR SMD 0805	27k OHM 5% 0.1W	ROHM	REEL a 5000 STK MCR 10 JZO J 273 E	302.065
R93-3	PRESET SEALED	50k OHM 25% 0.1W	BOURNS	REEL a 5000 STK 3374X-1-503-E (G)	310.450
R94-3	RESISTOR SMD 0805	22k OHM 5% 0.1W	ROHM	REEL a 750 STK MCR 10 JZO J 223 E	302.064
R95-3	RESISTOR SMD 0805	100k OHM 5% 0.1W	ROHM	REEL a 5000 STK MCR 10 JZO J 104 E	302.072
R96-3	RESISTOR SMD 0805	270k OHM 5% 0.1W	ROHM	REEL a 5000 STK MCR 10 JZO J 274 E	302.077
R97-3	RESISTOR SMD 0805	47k OHM 5% 0.1W	ROHM	REEL a 5000 STK MCR 10 JZO J 473 E	302.068
R98-3	RESISTOR SMD 0805	10k OHM 5% 0.1W	ROHM	REEL a 5000 STK MCR 10 JZO J 103 E	302.060
R99-3	RESISTOR SMD 0805	470k OHM 5% 0.1W	ROHM	REEL a 5000 STK MCR 10 JZO J 474 E	302.080
R100-3	RESISTOR SMD 0805	820 OHM 5% 0.1W	ROHM	REEL a 5000 STK MCR 10 JZO J 821 E	302.047
R101-3	RESISTOR SMD 0805	47 OHM 5% 0.1W	ROHM	REEL a 5000 STK MCR 10 JZO J 47R E	302.032
R102-3	RESISTOR SMD 0805	11k5 OHM 1% 50mW	PHILIPS	REEL a 5000 STK 2322 734 2/61153	302.476
R103-3	RESISTOR SMD 0805	36k5 OHM 1% 50mW	PHILIPS	REEL a 5000 STK 2322 734 2/63653	302.524
R104-3	RESISTOR SMD 0805	9k53 OHM 1% 50mW	PHILIPS	REEL a 5000 STK 2322 734 2/69532	302.464
R105-3	RESISTOR SMD 0805	121k OHM 1% 50mW	PHILIPS	REEL a 5000 STK 2322 734 2/61214	302.578
R106-3	RESISTOR SMD 0805	4k53 OHM 1% 50mW	PHILIPS	REEL a 5000 STK 2322 734 2/64532	302.433
R107-3	RESISTOR SMD 0805	487k OHM 1% 50mW	PHILIPS	REEL a 5000 STK 2322 734 2/64874	302.636
R108-3	RESISTOR SMD 0805	100k OHM 1% 50mW	PHILIPS	REEL a 5000 STK 2322 734 2/61004	302.570
R109-3	RESISTOR SMD 0805	205k OHM 1% 50mW	PHILIPS	REEL a 5000 STK 2322 734 2/62054	302.600
R110-3	RESISTOR SMD 0805	30k1 OHM 1% 50mW	PHILIPS	REEL a 5000 STK 2322 734 2/63013	302.516
R111-3	RESISTOR SMD 0805	487k OHM 1% 50mW	PHILIPS	REEL a 5000 STK 2322 734 2/64874	302.636
R112-3	RESISTOR SMD 0805	27k OHM 5% 0.1W	ROHM	REEL a 5000 STK MCR 10 JZO J 273 E	302.065
R113-3	RESISTOR SMD 0805	1k0 OHM 5% 0.1W	ROHM	REEL a 5000 STK MCR 10 JZO J 102 E	302.048
R114-3	RESISTOR SMD 0805	10k OHM 5% 0.1W	ROHM	REEL a 5000 STK MCR 10 JZO J 103 E	302.060
R115-3	RESISTOR SMD 0805	10k OHM 5% 0.1W	ROHM	REEL a 5000 STK MCR 10 JZO J 103 E	302.060
R116-3	RESISTOR SMD 0805	10k OHM 5% 0.1W	ROHM	REEL a 5000 STK MCR 10 JZO J 103 E	302.060
R117-3	RESISTOR SMD 0805	10k OHM 5% 0.1W	ROHM	REEL a 5000 STK MCR 10 JZO J 103 E	302.060
R118-3	RESISTOR SMD 0805	100k OHM 5% 0.1W	ROHM	REEL a 5000 STK MCR 10 JZO J 104 E	302.072
R119-3	RESISTOR SMD 0805	100k OHM 5% 0.1W	ROHM	REEL a 5000 STK MCR 10 JZO J 104 E	302.072
R120-3	RESISTOR SMD 0805	100k OHM 5% 0.1W	ROHM	REEL a 5000 STK MCR 10 JZO J 104 E	302.072
R121-3	RESISTOR SMD 0805	100k OHM 5% 0.1W	ROHM	REEL a 5000 STK MCR 10 JZO J 104 E	302.072

## 7 PARTS LIST

RM2042

POSITION	DESCRIPTION		MANUFACTOR	TYPE	S.P.NUMBER
R122-3	RESISTOR SMD 0805	10k OHM 5% 0.1W	ROHM	MCR 10 JZO J 103 E REEL a 5000 STK	302.060
R123-3	RESISTOR SMD 0805	10k OHM 5% 0.1W	ROHM	MCR 10 JZO J 103 E REEL a 5000 STK	302.060
R124-3	PRESET SEALED	50k OHM 25% 0.1W	BOURNS	3374X-1-503-E (G) REEL a 750 STK	310.450
R125-3	RESISTOR SMD 0805	120k OHM 5% 0.1W	ROHM	MCR 10 JZO J 124 E REEL a 5000 STK	302.073
R126-3	RESISTOR SMD 0805	100k OHM 5% 0.1W	ROHM	MCR 10 JZO J 104 E REEL a 5000 STK	302.072
R127-3	RESISTOR SMD 0805	100 OHM 5% 0.1W	ROHM	MCR 10 JZO J 101 E REEL a 5000 STK	302.036
R128-3	RESISTOR SMD 0805	680 OHM 5% 0.1W	ROHM	MCR 10 JZO J 681 E REEL a 5000 STK	302.046
R129-3	RESISTOR SMD 0805	3k9 OHM 5% 0.1W	ROHM	MCR 10 JZO J 392 E REEL a 5000 STK	302.055
R130-3	RESISTOR SMD 0805	2k2 OHM 5% 0.1W	ROHM	MCR 10 JZO J 222 E REEL a 5000 STK	302.052
R131-3	RESISTOR SMD 0805	2k2 OHM 5% 0.1W	ROHM	MCR 10 JZO J 222 E REEL a 5000 STK	302.052
R132-3	RESISTOR SMD 0805	27k OHM 5% 0.1W	ROHM	MCR 10 JZO J 273 E REEL a 5000 STK	302.065
R133-3	RESISTOR SMD 0805	100k OHM 5% 0.1W	ROHM	MCR 10 JZO J 104 E REEL a 5000 STK	302.072
R134-3	RESISTOR SMD 0805	100k OHM 5% 0.1W	ROHM	MCR 10 JZO J 104 E REEL a 5000 STK	302.072
TR1-3	TRANSFORMER	Fr=157MHz ADJUSTABLE	SUMIDA ELEC	S-7GD / 0237-1756	38.430
TR2-3	TRANSFORMER	2u7H ADJUSTABLE	TOKO	F292MNS-3342BQE	38.431
U1-3	INTEGRATED CIRCUIT	MC3372	MOTOROLA	MC3372	350.570
U2-3	INTEGRATED CIRCUIT	MSM6927	OKI	MSM6927GS-K	356.620
U3-3	QUAD OP.AMP.	LM324	TEXAS	LM324D	350.530
U4-3	INTEGRATED CIRCUIT	LM339	TEXAS	LM339D	350.540
U5-3	INTEGRATED CIRCUIT	74HC132D	TEXAS*	SN74HC132D	355.231
U6-3	INTEGRATED CIRCUIT	74HC4053T	PHILIPS	74HC4053T	355.313
U7-3	QUAD OP.AMP.	LM324	TEXAS	LM324D	350.530
U8-3	QUAD OP.AMP.	LM324	TEXAS	LM324D	350.530
U9-3	QUAD 2-INPUT NOR GATE	HCMOS	TEXAS	SN74HC02D	350.202
U10-3	VOLTAGE REG. ADJUSTABLE	Io=100mA LP2951C	NATIONAL	LP2951CM (LP2951ACM)	350.050
U11-3	VOLTAGE REGULATOR	5V/0.1A	MOTOROLA	MC78L05ACD	350.100
X1-3	CRYSTAL C1074	14.850MHz 10ppm NC18C	NDK	SP.SPEC: C1074	39.839
X2-3	CRYSTAL	3.579545MHz 50ppm HC49U	NDK	LN-P-0002-3.579545MHz SERIAL RESONANCE MODE	39.767
X3-3	CRYSTAL OVERTONE	141.225MHz 10ppm HC43/U	NDK	SP SPEC: C1099A	39.842
XR1-3	CERAMIC RESONATOR	Fr = 450kHz	MURATA	CDBM450C7	41.507

93/12

POSITION	DESCRIPTION		MANUFACTOR	TYPE	S.P.NUMBER
<b>DISPLAY PRINT</b>		<b>RM2042 / RM2150 / RM2151</b>	<b>ESPERA</b>	<b>5-0-26944E / 4-0-24944F</b>	<b>626944</b>
POSITION	DESCRIPTION		MANUFACTOR	TYPE	S.P.NUMBER
C1	CAPACITOR CERAM. SMD 0805	10nF 10% X7R 50VDC	MURATA	GRM40 X7R 103 K 50 PT REEL a 4000 STK	328.336
C2	CAPACITOR CERAM. SMD 0805	10nF 10% X7R 50VDC	MURATA	GRM40 X7R 103 K 50 PT REEL a 4000 STK	328.336
C3	CAPACITOR CERAM. SMD 0805	10nF 10% X7R 50VDC	MURATA	GRM40 X7R 103 K 50 PT REEL a 4000 STK	328.336
C4	CAPACITOR CERAM. SMD 0805	10nF 10% X7R 50VDC	MURATA	GRM40 X7R 103 K 50 PT REEL a 4000 STK	328.336
C5	CAPACITOR CERAM. SMD 0805	10nF 10% X7R 50VDC	MURATA	GRM40 X7R 103 K 50 PT REEL a 4000 STK	328.336
C6	CAPACITOR CERAM. SMD 0805	220pF 5% NPO 50VDC	MURATA	GRM40 COG 221 J 50 PT REEL a 4000 STK	323.090
D1	DIODE	BAS32L	PHILIPS	BAS32L	340.032
D2	DISPLAY LCD RM215x	2x24 CHARACTERS	SANYO	LCM 5023-31HE3	25.710
J1	SOCKET STRIP	7 POLES	ADV.INTERCONN	LNB-007-04-TG LSS-007-04-TG	78.835
J2	SOCKET STRIP	7 POLES	ADV.INTERCONN	LNB-007-04-TG LSS-007-04-TG	78.835
J3	SOCKET STRIP	3 POLES	ADV.INTERCONN	LNB-003-04-TG LSS-003-04-TG	78.831
J5	PLUG	1/10" SIL SQ.PINS 3 POLES	AMP	0-826629-3 (0-826647-3)	78.323
P1	Ø PIN STRIP	7 POLES	ADV.INTERCONN	KSA-007-80-G	78.376
P2	Ø PIN STRIP	7 POLES	ADV.INTERCONN	KSA-007-80-G	78.376
P3	Ø PIN STRIP	3 POLES	ADV.INTERCONN	KSA-003-80-G	78.372
P4	INTERCONNECTION CABLE	20 POLES L=87mm	ESPERA	3-0-26925A	526925
Q1	TRANSISTOR LF	BCP55-16 NPN SMD	SIEMENS	BCP55-16	345.355
R1	POTENTIOMETER	10k OHM 10% 0.1W LOG	NOBLE	V90-10155-D	08.257
R2	RESISTOR SMD 0805	100 OHM 5% 0.1W	ROHM	MCR 10 JZO J 101 E REEL a 5000 STK	302.036
R5	RESISTOR SMD 0805	100 OHM 5% 0.1W	ROHM	MCR 10 JZO J 101 E REEL a 5000 STK	302.036
R6	RESISTOR SMD 0805	36k5 OHM 1% 50mW	PHILIPS	2322 734 2/63653 REEL a 5000 STK	302.524
R7	RESISTOR SMD 0805	100 OHM 5% 0.1W	ROHM	MCR 10 JZO J 101 E REEL a 5000 STK	302.036
R8	RESISTOR SMD 0805	18k2 OHM 1% 50mW	PHILIPS	2322 734 2/61823 REEL a 5000 STK	302.495
R9	RESISTOR SMD 0805	9k09 OHM 1% 50mW	DRALORIC	CR 0805 K 9091 F G4 REEL a 5000 STK	302.462
R10	RESISTOR SMD 0805	4k53 OHM 1% 50mW	PHILIPS	2322 734 2/64532 REEL a 5000 STK	302.433
R11	RESISTOR SMD 0805	1k5 OHM 5% 0.1W	ROHM	MCR 10 JZO J 152 E REEL a 5000 STK	302.050
R12	RESISTOR NTC	4K7 OHM 10% 0.25W	SIEMENS	B57621-C472-K62	306.810
R13	RESISTOR SMD 0805	2k2 OHM 5% 0.1W	ROHM	MCR 10 JZO J 222 E REEL a 5000 STK	302.052
R14	RESISTOR SMD 0805	2k2 OHM 5% 0.1W	ROHM	MCR 10 JZO J 222 E REEL a 5000 STK	302.052
R15	RESISTOR SMD 0805	47k OHM 5% 0.1W	ROHM	MCR 10 JZO J 473 E REEL a 5000 STK	302.068
R16	RESISTOR SMD 0805	47k OHM 5% 0.1W	ROHM	MCR 10 JZO J 473 E REEL a 5000 STK	302.068
R17	RESISTOR SMD 0805	4k53 OHM 1% 50mW	PHILIPS	2322 734 2/64532 REEL a 5000 STK	302.433
R18	RESISTOR SMD 0805	47k OHM 5% 0.1W	ROHM	MCR 10 JZO J 473 E REEL a 5000 STK	302.068
R19	RESISTOR SMD 0805	47k OHM 5% 0.1W	ROHM	MCR 10 JZO J 473 E REEL a 5000 STK	302.068
R20	RESISTOR SMD 0805	120k OHM 5% 0.1W	ROHM	MCR 10 JZO J 124 E REEL a 5000 STK	302.073
R21	RESISTOR SMD 0805	36k5 OHM 1% 50mW	PHILIPS	2322 734 2/63653 REEL a 5000 STK	302.524
R22	RESISTOR SMD 0805	1k2 OHM 5% 0.1W	ROHM	MCR 10 JZO J 122 E REEL a 5000 STK	302.049
R23	RESISTOR SMD 0805	18k2 OHM 1% 50mW	PHILIPS	2322 734 2/61823	302.495

92/47

## 7 PARTS LIST

RM2042

POSITION	DESCRIPTION		MANUFACTOR	TYPE	S.P.NUMBER
R24	RESISTOR SMD 0805	1k30 OHM 1% 50mW	DRALORIC	REEL a 5000 STK CR 0805 K 1301 F G4	302.381
R25	RESISTOR SMD 0805	5R6 OHM 5% 0.1W	ROHM	REEL a 5000 STK MCR 10 JZO J 5R6 E	302.021
R26	RESISTOR SMD 0805	10k OHM 5% 0.1W	ROHM	REEL a 5000 STK MCR 10 JZO J 103 E	302.060
R27	RESISTOR SMD 0805	120k OHM 5% 0.1W	ROHM	REEL a 5000 STK MCR 10 JZO J 124 E	302.073
R28	RESISTOR SMD 0805	5R6 OHM 5% 0.1W	ROHM	REEL a 5000 STK MCR 10 JZO J 5R6 E	302.021
U1	INTEGRATED CIRCUIT	74HC174D	TEXAS*	REEL a 5000 STK SN74HC174D	355.252
U2	QUAD OP.AMP.	LM324	TEXAS	LM324D	350.530
U4	INTEGRATED CIRCUIT	74HC14D	TEXAS*	SN74HC14D	355.213
U5	INTEGRATED CIRCUIT	74HC04D	TEXAS*	SN74HC04D	355.205
W1	SHUNT CONNECTOR	FEMALE 2 POLES	SAMTEC	SNT-100-BK-G	78.325



